

VARIO VT 20 **Girder Wall Formwork**

Assembly Instructions for Standard Configuration

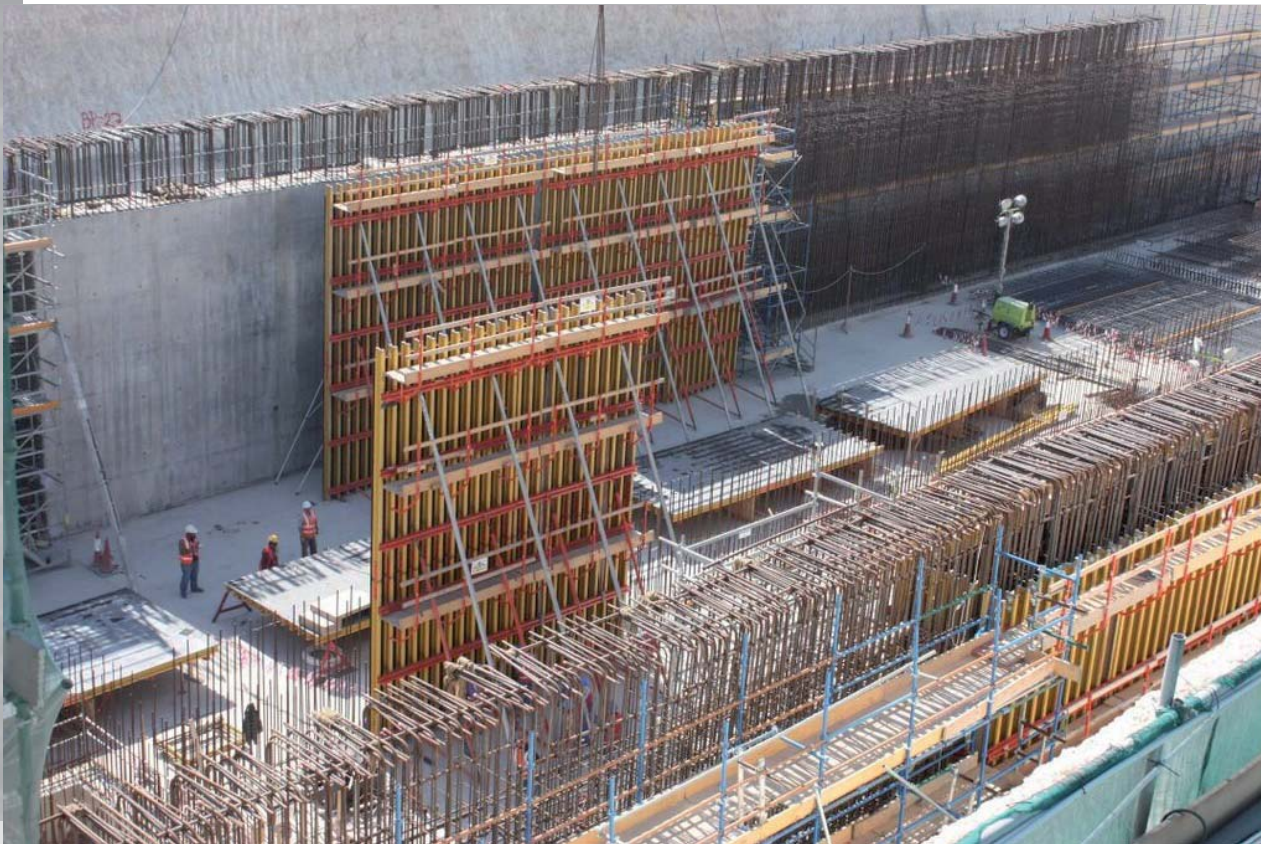

Content

Introduction

Overview, Main Components	1
Intended Use	3
Instructions for Use	3
Target Groups	4
Additional Technical Documentation	4
Cross-System	5
System-Specific	6
Storage and Transportation	6

A General, Element Assembly

A1 Maintenance and cleaning	7
A2 Panel Assembly	9
A3 Assembly of Internal Corner with VSRZ	11
A4 Filler Element	13
A5 Hook Strap for VT, HBU, HBUD	15

B Working on the construction site

B1 Push-pull Props and Kicker Braces	17
B2 Working and concreting concreting Platform, Scaffold Bracket GB-VT	19
B3 Lifting unit	
Crane Splice-2 VT 20	20
B4 External corners	21
B5 Internal corners	23
B6 Panel connections	25
B7 Length Compensations	26
B8 Anchoring	27
B9 Stopped formwork	28
B10 Height extensions	29

C Application

C1 T-junctions 90°	31
Obtuse wall connection	
C2 Oblique angle	32
C3 Elements connections for architectural concrete	33

D System supplements

D1 Steel Waler SRU, SRZ	34
D2 Universal Coupling UK 70	36

Product overview

Components	37
------------	----

Key



Safety Instructions



Note



Visual Check



Tip



Load-bearing point

Introduction

Overview, Main Components

- A1 Element
- A2 Internal corner
- A3 Filler element
- B1 Push-pull props
- B2 Working and concreting scaffold
- B3 Lifting unit
- B4 / B5 External corner
- B6 Panel connections
- B7 Length compensations
- B8 Anchor
- B9 Stopped formwork

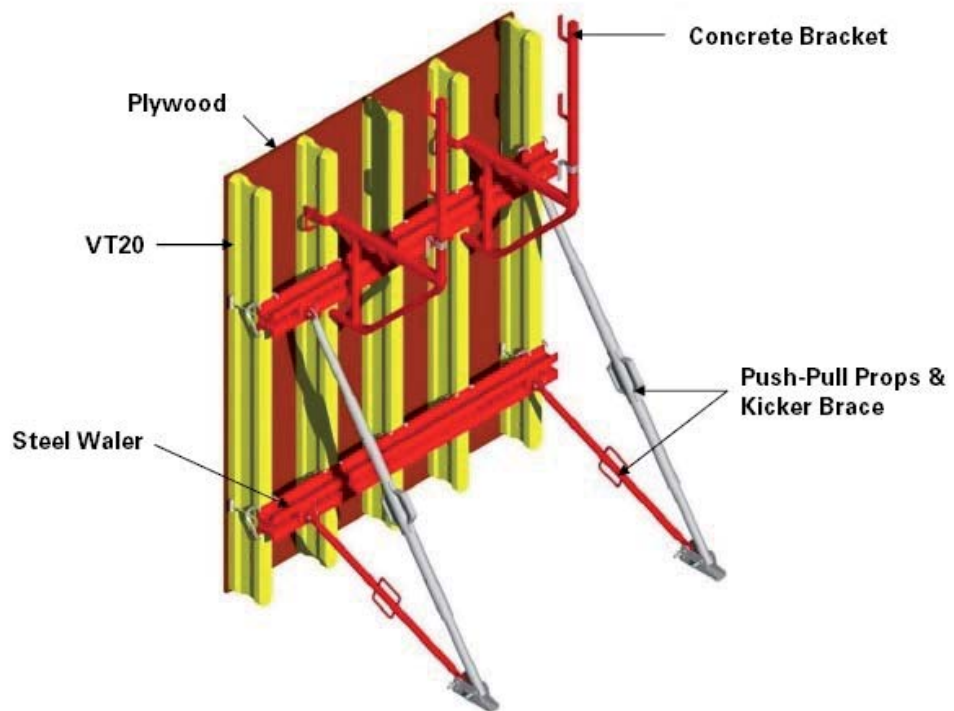

Element width

The element width is determined by the length of the SRZ or SRU steel walers.

Element height

The element height is determined by the VT 20 girder length.
 The VT 20 girder is available in lengths ranging from 1.45 m to 5.90 m. Special lengths of up to 11.90 m are also available.

Fresh concrete pressure

The fresh concrete pressure is determined by the planning engineer. The elements must be installed according to the specifications.

Basic element

- 1 VARIO panel
- 2 Girder VT 20
- 3 Steel Waler SRZ/SRU
- 4 Hook Strap HB/HBU
- 5 Formlining
- 6 Formlining fixing (Torx)
- 7 Crane Splice-2 VT 20

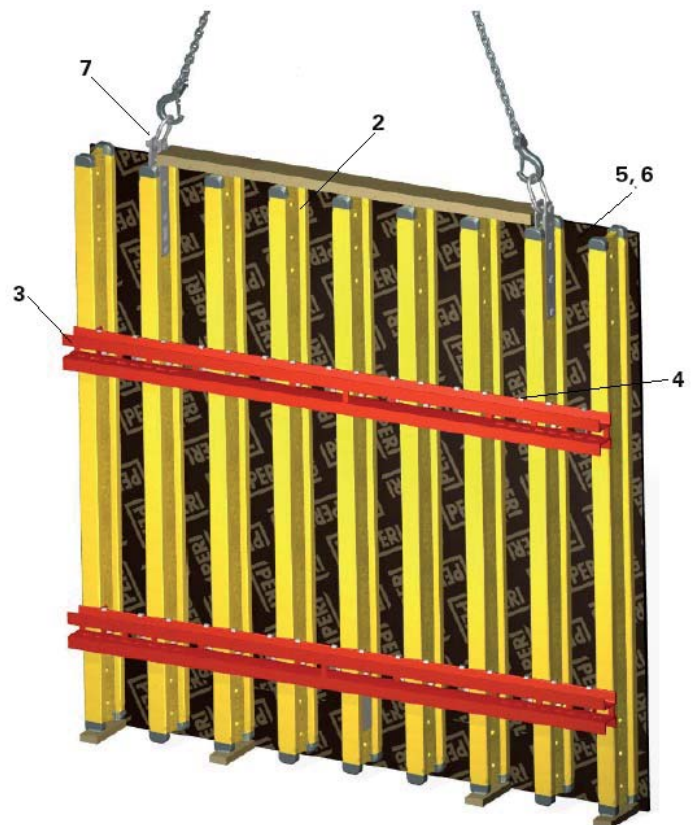

Introduction

Intended Use

Product description

PERI products have been designed for exclusive use in the industrial and commercial sectors only by suitably trained personnel.

PERI VARIO is a girder formwork system used for forming walls and columns as well as residential, industrial and civil engineering construction. Through the freely selectable arrangement of the individual element components, the formwork can be adapted to suit a wide range of requirements such as element width and height, fresh concrete pressure and concrete surface. The element is assembled according to project specifications. The PERI VT 20 is the cost-effective, 20 cm high solid web girder complete with optimal protection at the girder end. The longitudinally-shaped holes in the steel walers and couplings result in the possibility of continuously variable tight connections (tension and compression) in all applications.

System dimensions

The VT 20 girder is available in standard lengths of 1.45 m - 5.90 m. Special lengths of up to 11.90 m are also available. Square or rectangular column cross sections are possible and can be continuously formed up to 1.20 m x 1.20 m.

Application

The standard configuration is comprised of formwork for vertical walls up to 12.00 m high, including push-pull props and safety equipment. Formwork for, e.g. inclined walls, climbing formwork (see PERI climbing systems) and moving the formwork without the use of a crane, is not covered by the intended use provisions and is to undergo a separate check.

Permissible fresh concrete pressure according to DIN 18218

Evenness according to DIN 18202, Table 3, Line 7.

Instructions for Use

The use in a way not intended, deviating from the standard configuration or the intended use according to the Instructions for Assembly and Use, represents a misapplication with a potential safety risk, e.g. risk of falling.

Only PERI original components may be used. The use of other products and spare parts is not allowed.

Changes to PERI components are not permitted.

Introduction

Target Groups

Contractor

These Instructions for Assembly and Use are designed for contractors who use the formwork systems for

- assembling, modifications and dismantling or
- e.g. concreting or
- for other operations, e.g. carpentry or electrical work

Construction site coordinator

The Safety and Health Protection Coordinator*

- is appointed by the client,
- must identify potential hazards during the planning phase,
- determines measures that provide protection against risks,
- creates a safety and health plan,
- coordinates the protective measures for the contractor and site personnel so that they do not endanger each other,
- monitors and ensures compliance with the protective measures.

Qualified and competent personnel

Due to the specialist knowledge gained from professional training, work experience and recent professional activity, the qualified person has a reliable understanding of safety-related issues and can correctly carry out tests.

Depending on the complexity of the test to be undertaken, e.g. scope of testing, type of testing or the use of a certain measuring device, a range of specialist knowledge is necessary.

Qualified specialists

Formwork systems may only be assembled, modified or dismantled by personnel who are suitably qualified to do so. For the work to be carried out, the qualified workers must have received instructions** which contain at least the following points:

- An explanation of the plan for the assembly, modification or dismantling of the formwork system in an understandable form and in the language of the user.
- Description of measures in order to safely assemble, modify or dismantle the formwork system.
- Designation of the preventive measures to avoid the risk of persons and objects falling.

- Designation of the safety precautions in the event of changing weather conditions which could adversely affect the safety of the formwork system concerned as well as the personnel.
- Details regarding the permissible loads.
- Description of any other risks that are associated with the assembly, modification or dismantling procedures.



In other countries, ensure that the relevant national guidelines and regulations in the respective current version are complied with!

* Valid in Germany: Regulations for Occupational Health and Safety on Construction Sites 30 (RAB 30).

** Instructions are given by the contractor himself or a qualified and competent person selected by him.

Additional Technical Documentation

- Instructions of Use for Pallets and Stacking Devices.
- PERI design tables.
- VARIO VT 20 brochure.

Introduction

Cross-System

General

The contractor must ensure that the Instructions for Assembly and Use supplied by PERI are available at all times and are understood by the site personnel.

These Instructions for Assembly and Use can be used as the basis for creating a risk assessment. The risk assessment shall be compiled by the contractor. The Instructions for Assembly and Use do not replace the risk assessment!

Always take into consideration and comply with the safety instructions and permissible loads.

For the application and inspection of PERI products, the current safety regulations and guidelines must be observed in the respective countries where they are being used.

Materials and working areas are to be inspected on a regular basis especially before each use and assembly for:

- signs of damage,
- stability and
- functionality.

Damaged components must be exchanged immediately on site and may no longer be used.

Safety components are removed only when they are no longer required.

Components provided by the contractor must conform with the characteristics required in these Instructions for Assembly and Use as well as all valid construction guidelines and standards. Unless otherwise indicated, this applies in particular to:

- timber components: Strength Class C24 for Solid Wood according to EN 338,
- scaffold tubes: galvanised steel tubes with minimum dimensions of $\varnothing 48,3 \times 3,2$ mm according to EN 12811-1:2003 4.2.1.2.
- scaffold tube couplings according to EN 74.

Deviations from the standard configuration are only permitted after a further risk assessment has been carried out by the contractor. On the basis of this risk assessment, determine appropriate measures for working and operational safety as well as stability.

Corresponding proof of stability can be provided by PERI on request if the risk assessment and resulting measures to be implemented are made available.

Before and after exceptional occurrences that may have an adverse effect on the safety of the formwork system, the contractor must immediately

- create another risk assessment, with appropriate measures for ensuring the stability of the formwork system being carried out based on the results,
- and arrange for an extraordinary inspection by a qualified and competent person. The aim of this inspection is to identify and rectify any damage in good time in order to guarantee the safe use of the formwork system.

Exceptional occurrences can include:

- accidents,
- longer periods of non-use,
- natural events, e.g. heavy rainfall, icing, heavy snowfall, storms or earthquakes.

Assembly, modification and dismantling work

Assembly, modification or dismantling of formwork systems may only be carried out by qualified personnel under the supervision of an authorized person. The qualified personnel must have received appropriate training for the work to be carried out with regard to specific risks and dangers.

On the basis of the risk assessment and Instructions for Assembly and Use, the contractor must create installation-instructions in order to ensure safe assembly, modification and dismantling of the formwork system.

The contractor must ensure that the personal protective equipment required for the assembly, modification or dismantling of the system, e.g.

- safety helmet,
 - safety shoes,
 - safety gloves,
 - eye protection,
- is available and used as intended.

If personal protective equipment (PPE) is required or specified in local regulations, the contractor must determine -appropriate load-bearing points on the basis of the risk assessment.

The personal protective equipment to be used is determined by the contractor.

The contractor must

- provide safe working areas for site personnel which can be reached through the provision of safe access ways. Areas of risk must be cordoned off and clearly marked,
- ensure the stability during all stages of construction, in particular during assembly, modification and dismantling of the formwork,
- ensure and prove that all loads are safely transferred.

Utilization

Every contractor who uses or allows formwork systems or sections of the formwork to be used, has the responsibility to ensure that the equipment is in good condition.

If the formwork system is used successively or at the same time by several contractors, the health and safety coordinators must point out any possible mutual hazards and all work must be then coordinated.

Introduction

System-Specific

Retract components only when the concrete has sufficiently hardened and the person in charge has given the go-ahead for striking to take place.

Anchoring is to take place only if the anchorage has sufficient concrete strength.

During striking, do not tear off the formwork elements with the crane.

If a storm warning is given, additional push-pull props are to be attached or other bracing measures are to be -carried out along with implementing the bracing specified in the PERI design tables.

Storage and Transportation

Store and transport components ensuring that no unintentional change in their position is possible. Detach load-bearing devices and lifting gear from the components that have been set down only if they are in a stable position and no -unintentional change is possible.

Do not drop the components.

Use PERI load-bearing devices and lifting gear as well as only those load-bearing points provided on the component.

During the moving procedure,

- Ensure that components are picked up and set down so that unintentional falling over, falling apart, sliding, falling down or rolling is avoided,
- No persons are allowed to remain under the suspended load

The access areas on the jobsite must be free of obstacles and tripping hazards as well as being slip-resistant.

For transportation, the surface must have sufficient load-bearing capacity.

Use original PERI storage and transport systems, e.g. crate pallets, pallets or stacking devices.

A1 Maintenance and cleaning

Care and Maintenance Instructions

In order to maintain the value and operational readiness of the formwork materials over the long term, clean the elements after each use.

Some repair work may also be inevitable due to the tough working conditions.

The following points should help to keep care and maintenance costs as low as possible.

Spray the formwork on both sides with the concrete release agent before each use; this allows easier and faster cleaning of the formwork. Spray the concrete release agent very thinly and evenly!

Spray the rear side of the formwork with water immediately after concreting; this avoids any time-consuming and costly cleaning operations.

When used continuously, spray the panel formlining with the concrete release agent immediately after striking; then clean by means of a scraper, brush or rubber lip scraper. Important: do not clean formlining made of plywood with high-pressure equipment; this could result in the formlining being damaged.

Fix box-outs recesses and mounting parts with double-headed nails; as a result, the nails can be easily be subsequently removed, and damage to the formlining is largely avoided.

Close all unused anchor holes with plugs; this eliminates any subsequent cleaning or repair work. Anchor holes accidentally blocked with concrete are freed by means of a steel pin from the formlining side.

When placing bundles of reinforcement bars or other heavy objects on horizontally-stored formwork elements, suitable support, e.g. square timbers, is to be used; as a result, impressions and damage to the formlining are largely avoided.

Internal concrete vibrators should be fitted, if possible, with rubber caps; as a result, any damage to the formlining is reduced if the vibrator is accidentally inserted between the reinforcement and formlining.

Never clean powder-coated components, e.g. elements and accessories, with a steel brush or hard metal scraper; this ensures that the powder-coating remains intact.

Use spacers for reinforcement with a large-sized supports or extensive areas of support; this largely avoids impressions being formed in the formlining when under load.

Mechanical components, e.g. spindles or gear mechanisms, must be cleaned of dirt or concrete residue before and after use, and then greased with a suitable lubricant.

Provide suitable support for the components during cleaning so that no unintentional change in their position is possible.

Do not clean components when suspended on a crane.

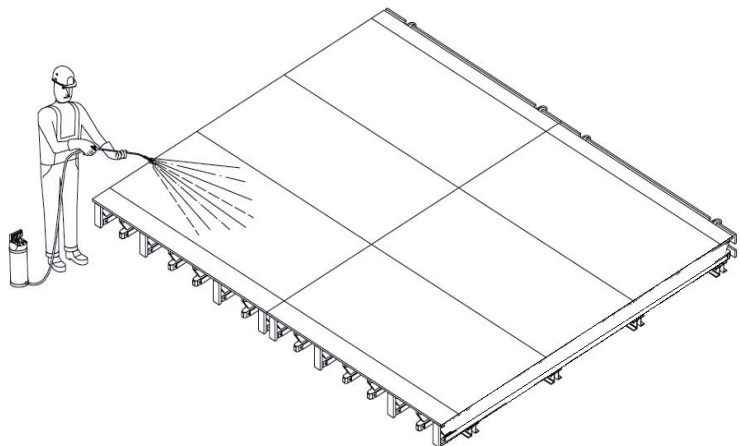

Fig. A1.01

A2 Element Assembly

1. On a sufficiently large and flat assembly area, mount stopping boards for the steel walers and girder spacing battens according to the assembly plans.



With subsequent use of the GB 80-VT Scaffold Bracket, the girder spacing must be at least 20 cm.

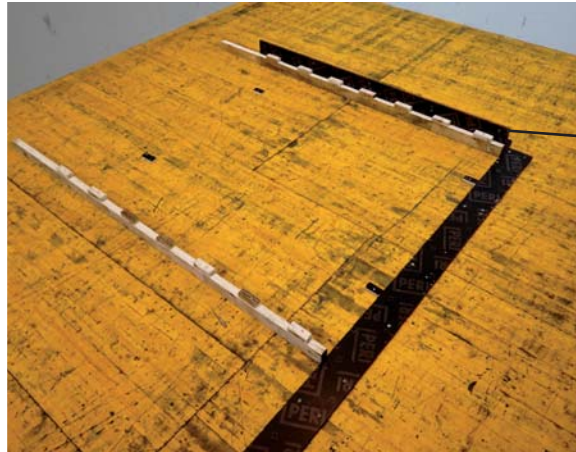

16-20 cm depending on waler

2. Position the steel walers. Make sure they are placed directly against the stopping boards. For steel walers without end plates, the cut outs in the longitudinal holes must point to the concrete side, i.e. upwards.

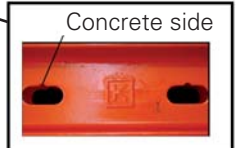
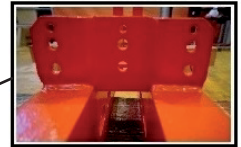
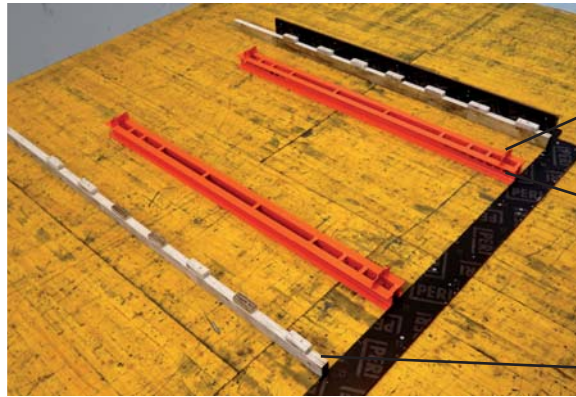

9-13 cm depending on waler

3. Position edge beam against the steel waler and secure.

Fastening takes place with:

- HBU Hook Strap.
- or
- TSS Torx 6x60

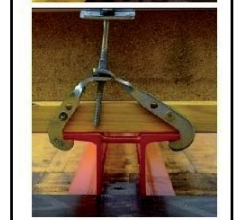
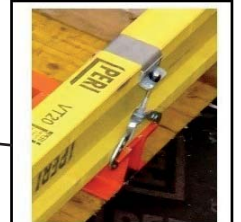
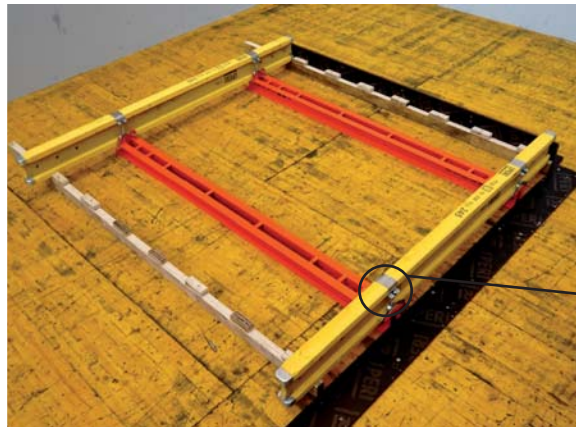

4. position intermediate girder and align on spacing battens.



For later extensions, ensure stopping board is free of any obstructions.

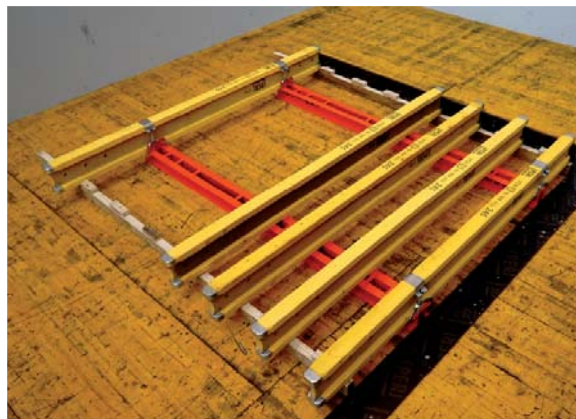

A2 Element Assembly

5. Mount hook strap for VT and distribute it in staggered way



Alternate fixing of the girders ensures even contact pressure.

Girders having crane splice should be fixed by two hook strap for VT with each SRZ waler.

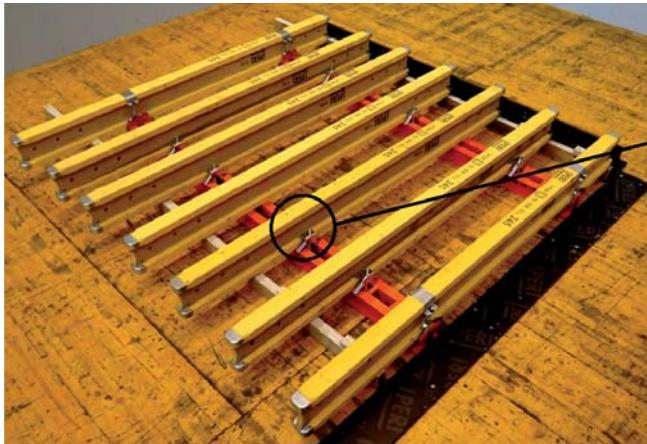

6. Position formlining and fix first sheet by means of nails.

Projecting length X: SRZ = 25 mm
SRU = 15 mm

Fix using approx. 10 TSS Torx 6 x 60, or TSS Torx 6 x 60 ZKS pro m².



Pay attention to projecting lengths of the formlining at the top and bottom when extending later on.

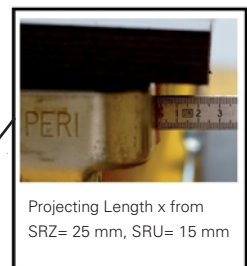
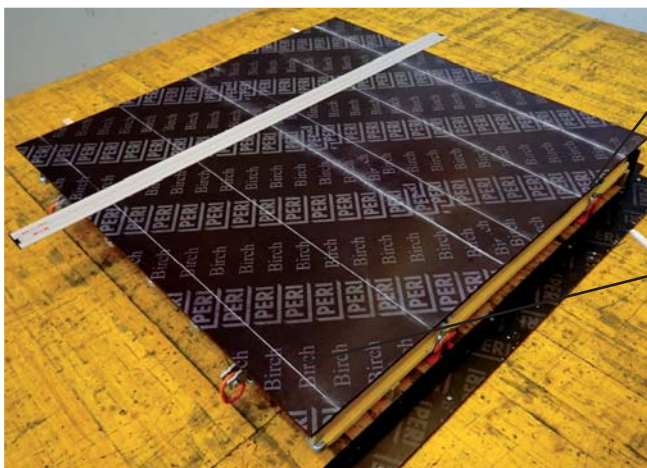

7. Mark position of tie holes and drill holes with a Ø 20 mm bit.



Seal cut edges and drilled holes. Pay attention to projecting lengths.



8. If necessary, mount Crane Splice-2 VT 20 at the top and rubbing boards at the bottom.

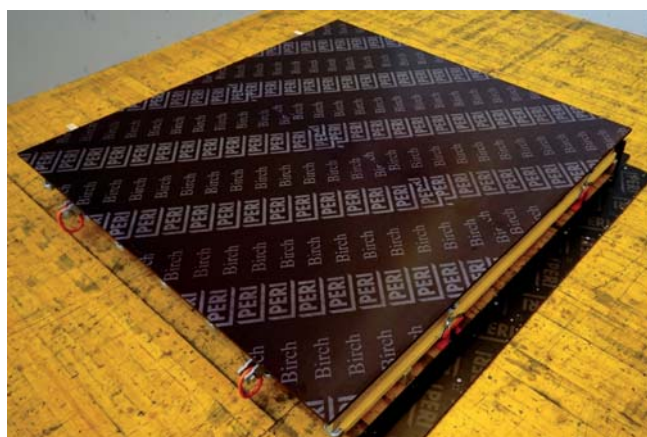

A3 Assembly of Internal Corner with VSRZ

1. Lay the VSRZ Steel Waler on the assembly area. Make sure it is placed directly against the stopping board. The long stub points upwards.

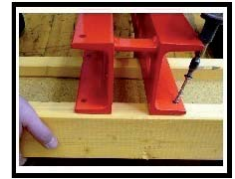

2. Position the VT 20 girder, use screw TSS-Torx to hold in position and fix it through holes found in the VSRZ waler.

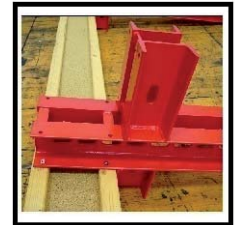

Tighten TSS-Torx alternately with an impact screwdriver.



3. Position edge beam against the steel waler and secure.

Fastening takes place with:

– HBU Hook Strap.

or

– TSS Torx 6x60.

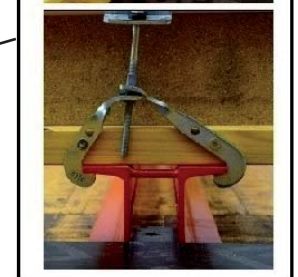
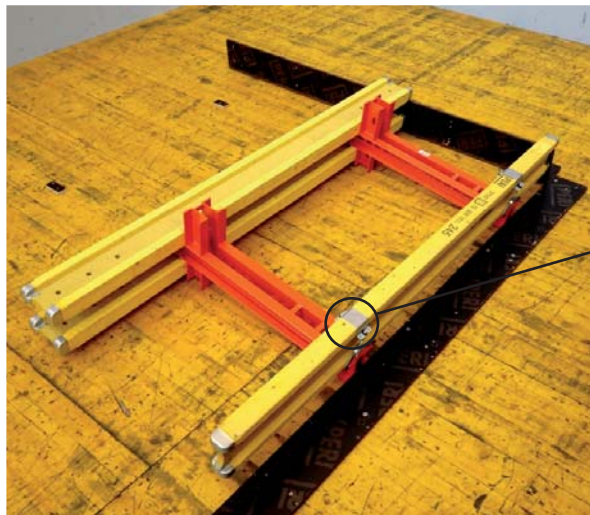

4. Position corner girder, use Hook Strap for VT to hold in position and fix it to the stub by means of TSS-Torx screw.



A3 Assembly of Internal Corner with VSRZ

5. Install spacers timber by fixing it above the corner girder using TSS-Torx. Then position additional girder and fix it by using TSS-Torx 6x60 through the existed hole in VSRZ Waler.



Check the angle on each waler.

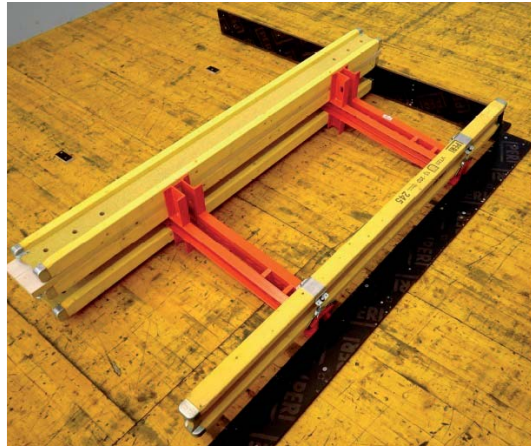

6. Place and align intermediate girder and secure using the Hook Strap for VT.



For later extensions, ensure stopping board is free of any obstructions. Girders having crane splice should be fixed by two hook strap for VT with each SRZ waler.



7. Position formlining and then secure. Fix using approx. 10 TSS Torx 6 x 60, or TSS Torx 6 x 60 ZKS pro m². Drill holes with a Ø 20 mm bit.



Seal cut edges and drilled holes. Pay attention to projecting lengths.

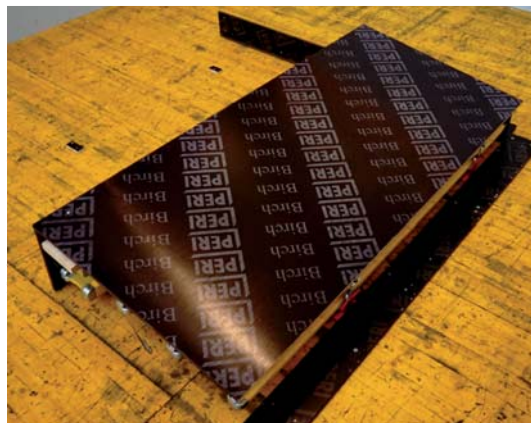

8. If necessary, mount Crane Splice-2 VT20 at the top and rubbing boards at the bottom.

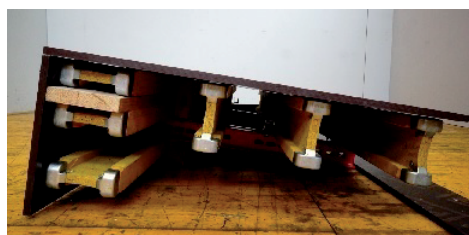

A4 Filler Element

Filler element

Maximum width compensation:

VKZ 147 = 0.48 m

VKZ 211 = 1.20 m

The filler element (10) is used for longitudinal compensation. VKZ 147 or VKZ 211 (11) couplings are used for this purpose. (Fig. A4.01)

Cutting the filler plate

Cut = compensation space

Assembly

1. Maintain girder spacings as with VARIO elements.
2. Plywood projects over left and right edges by 2.5 cm.
3. Mount coupling compression plate (12) to each VT 20 girder at the level of the steel waler and secure with K-wedges (13).
4. Fix diagonals using wood screws M8 x 60 (6.2).
5. Brace VT 20 girder to prevent tipping, e.g. with plywood strips.
6. Provide tie holes depending on the filler area. (Fig. A4.02)

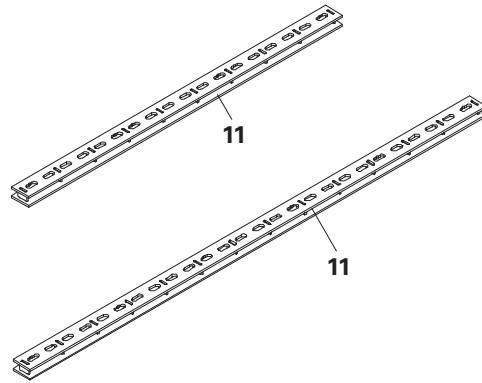

Fig. A4.01

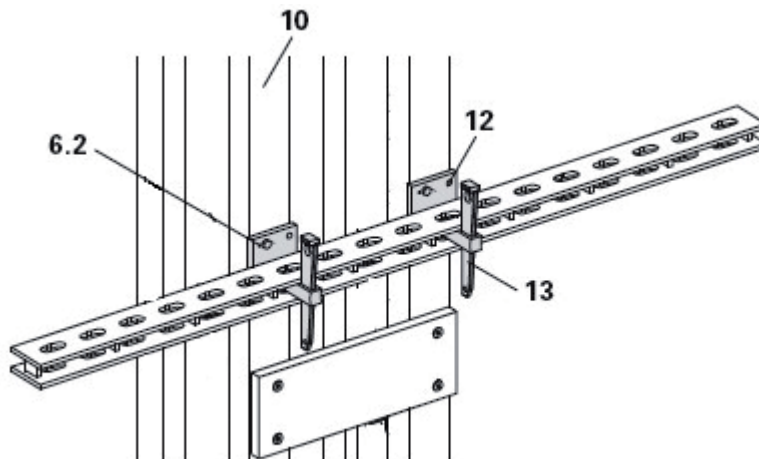
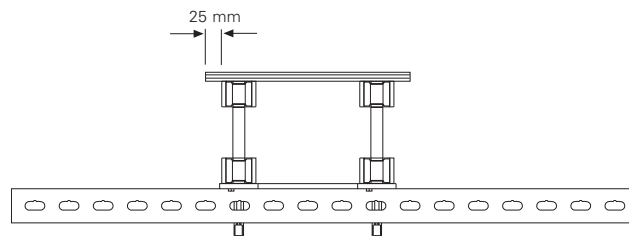

Fig. A4.02



A5 Hook Strap for VT, HBU, HBUD

**Universal Hook Strap HBU 20-24
Universal Hook Strap 24-28**

- For 1 x Girder GT 24, VT 20.
- For timbers.
- For Steel Walers SRZ and SRU U100 - U140.
- Can also be used outside of the node point.

**Universal Hook Strap HBUD 20-24
Universal Hook Strap HBUD 24-28**

- For 2 x Girder GT 24, VT 20.
- For timbers.
- For Steel Walers SRZ and SRU U100 - U140.
- Can also be used outside of the node point.



Standard application:

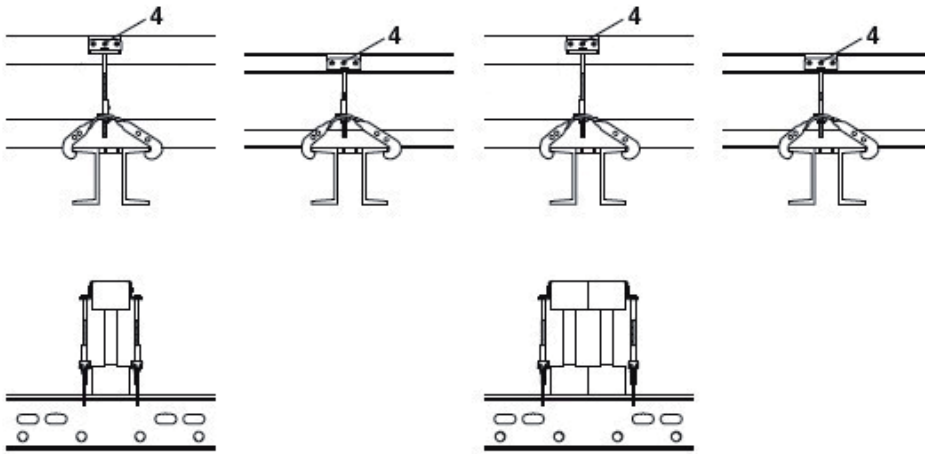

With filler:
up to 8 cm

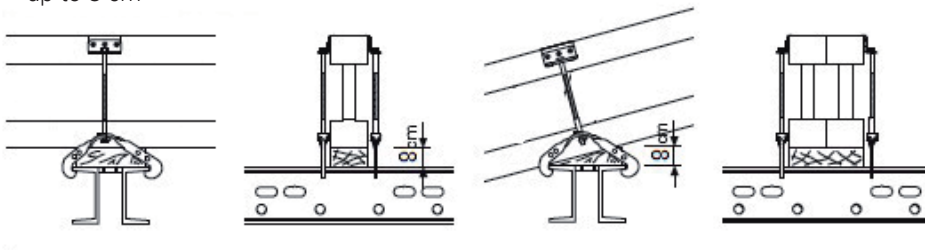

For edge beam:

with Steel Waler SRZ with end plate and Hook Strap HBU and HBUD.

Inner side:

secure girder with 1 x TSS Torx 6 x 60 (6.1).

Outer side:

secure girder with 2 x TSS Torx 6 x 60 (6.1).

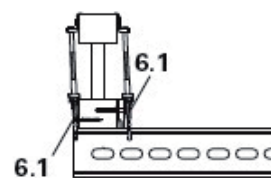
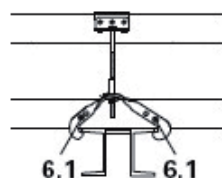
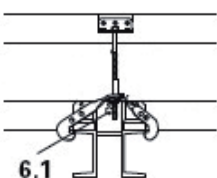

A5 Hook Strap for VT, HBU, HBUD

Girder positioned at an angle to the steel waler

Up to 15° possible with the Hook Strap HBU.



In addition, the long hooks (short hooks) have to point in opposite directions.

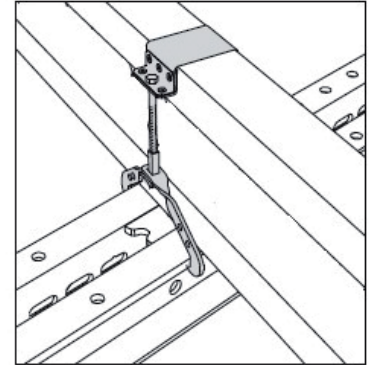
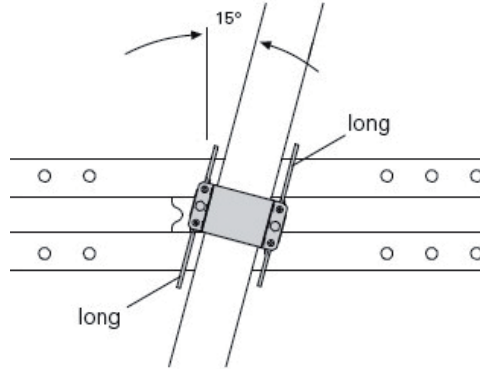

Hook Strap for VT Standard application

- For VT 20.
- For Steel Walers SRZ and SRU U100 - U140.

Girder positioned at an angle to the steel waler

Up to 10° possible with the Hook Strap VT.

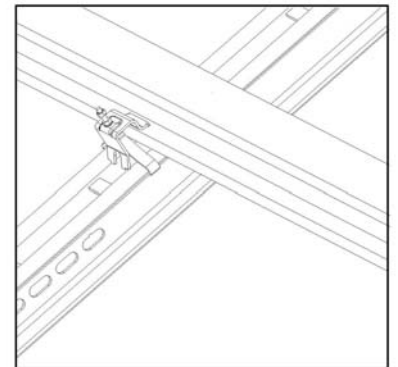
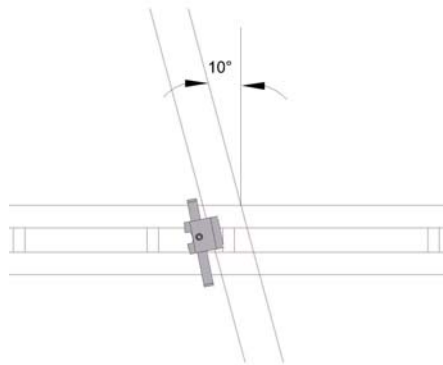

B1 Push-Pull Props and Kicker Braces

Standard application

		Formwork height h [m] System 1						Formwork height h [m] System 2				
		3.00	4.00	5.00	6.00	7.00	8.00	9.00	10.00	11.00	12.00	
Permissible width of influence [m]	EB_{ref}	3.77	2.92	2.30	1.90	1.72	1.49	2.10	1.77	1.54	1.30	
Actual push-pull prop load [kN]	F_{RS1}	11.5	11.5	11.5	11.5	11.5	11.5	11.5	11.0	11.5	11.5	
	F_{RS2}							10.9	11.5	11.2	10.5	
Actual kicker load [kN]	F_{AV}	2.7	2.9	2.8	2.7	3.2	3.5	4.2	3.6	3.4	8.9	
Base plate	Resulting force [kN]	①	13.7	13.7	13.5	13.4	13.7	13.9	11.5	11.0	11.5	11.5
		②							14.2	14.3	13.7	12.8
	Angle of resulting vector [°]	①	52.4	51.1	51.1	51.1	49.4	48.2	60.0	60.0	60.0	60.0
		②							47.9	49.8	49.9	49.8
Lifting force V_{Wind} [kN/m]		2.88	3.65	4.57	5.48	6.02	6.92	9.78	11.52	13.25	15.22	
x = Distance of base plate [m] from rear side of formwork	x_1	1.2	1.6	2.0	2.4	3.0	3.6	4.2	4.7	5.1	5.5	
	x_2							2.6	2.6	2.8	3.0	
y = Top connection point from top of formwork [m]	y_1	1.0	1.2	1.5	1.8	1.8	1.8	1.5	1.8	2.1	2.4	
	y_2							4.5	5.5	6.2	6.9	
$q_{stand} = q(z) \times \kappa$ [kN/m ²]		0.41	0.41	0.41	0.41	0.41	0.43	0.45	0.46	0.48	0.50	

Load assumptions:

- wind loads according to DIN 1055-4:2005-03
- inland, Wind Load Zone 2
- standard area (see diagram below)
- assumed aerodynamic coefficient $c_p = 1.8$
- vertical formwork on ground
- statistical factor $\kappa = 0.7$
- inclination of the push-pull prop to the horizontal 60°
- values are characteristic values.

In the end area L_E the following c_{p-} values or wind loads are assumed:

- $L/h \leq 3$: $c_{p, End} = 2.3^*$
- $L/h = 5$: $c_{p, End} = 2.9^*$
- $L/h \geq 10$: $c_{p, End} = 3.4^*$
- L_E = longer end area ($0.3 \times h$)
- h = formwork height
- L = formwork length

*intermediate values are interpolated

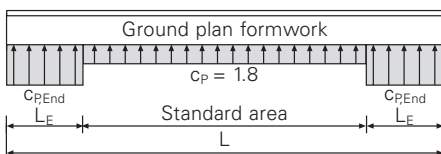

System 2

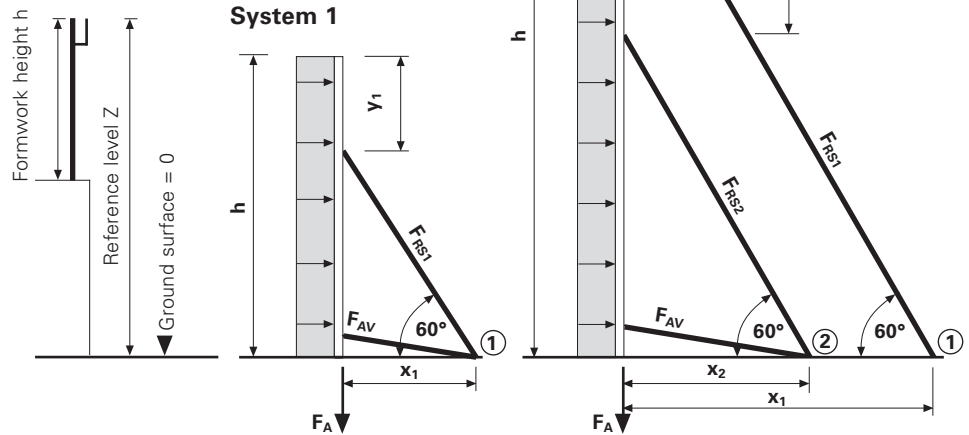

For anchoring (lifting) force $F_A = 1.5 \times V_{Wind} - 0.9 \times G \times h$
 G = surface area weight of the formwork including platforms

B1 Push-Pull Props and Kicker Braces

Push-Pull Props

Push-pull props and kicker braces are fixed with the wedge headpiece to the steel waler. (Fig. B1.01 & Fig. B1.02)

Assembly of Wedge Headpiece

For U100, U120 and U140 profiles.

1. Push piece with wedge opening through the steel waler profile.
2. Choose opening according to the profile.
3. Insert K-wedge and hammer in tightly.

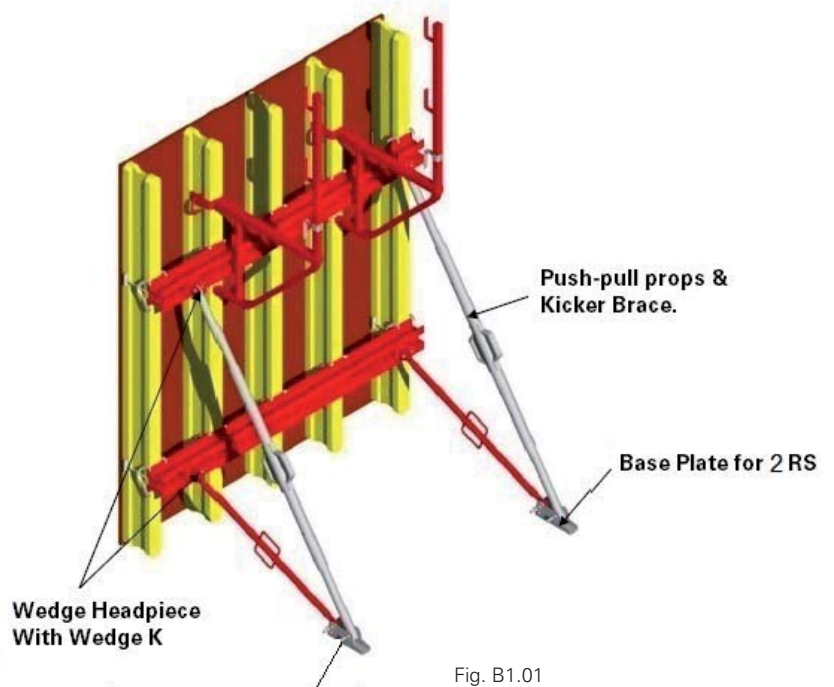

Fig. B1.01

Assembly of Push-Pull Props and Kicker Braces

Fix push-pull props and kicker braces with bolts and cotter pins in the same way to the base plate-2RS.

Permissible push-pull prop spacing: see Table.

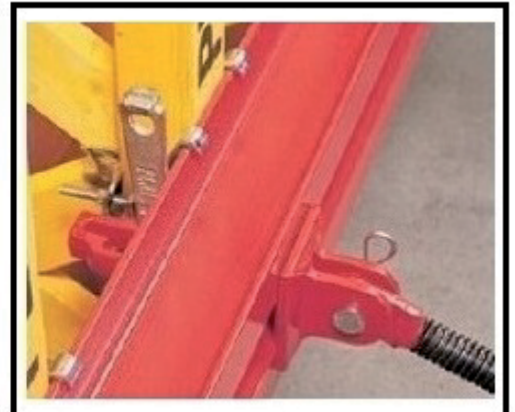
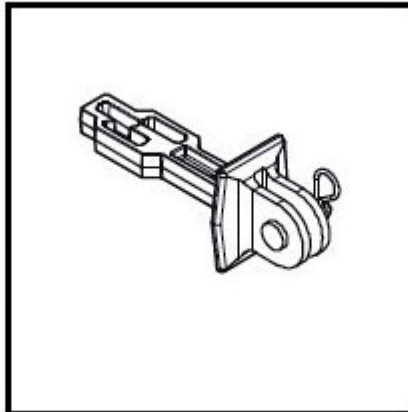
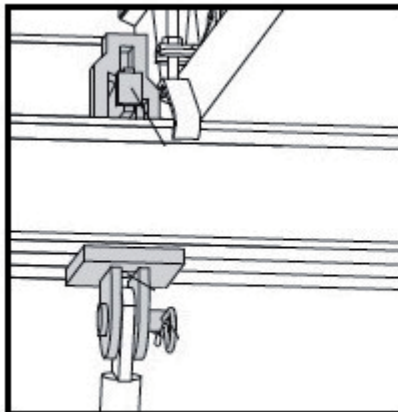
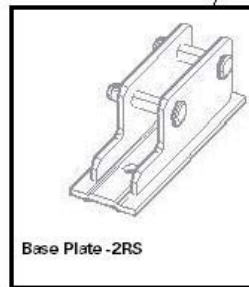

Fig.B1.02

Connecting to Steel Waler SRZ with the Wedge Headpiece, Item no. 028060 and Wedge K, Item no. 024250.

B2 Working and Concreting Platform

Scaffold Bracket GB 80-VT



**Permissible load capacity of 150 kg/m².
Maximum width of influence 1.25 m.
Secure planking.
Decking components and guardrails
must be mounted securely in position at all times.**

A working and concreting scaffold consists of:

- Scaffold Bracket GB 80-VT (20)
 - Corner Scaffold Bracket EGB 80L, R
 - planking (21)
 - guardrails including boards (22)
 - lateral guardrails (23).
- (Fig. B2.01.1 + B2.01.2)

Assembly on horizontally-positioned element

1. Remove Pin B 20x120-ST-VZ and cotter Pin FS 4/1. Then place scaffold bracket with U-profile on the girder.
2. Secure locking pin and secure screwing the pin with cotter pin passing through the standard hole of VT 20.
3. Fix planking across complete bracket width from below using Torx 6 x40.
4. Mount and secure guard rails including boards (and lateral guardrails if necessary).
5. To position bracket where no standard hole is available additional ones of diameter 22mm can be drilled in the middle of the web having a gap greater than 150mm.

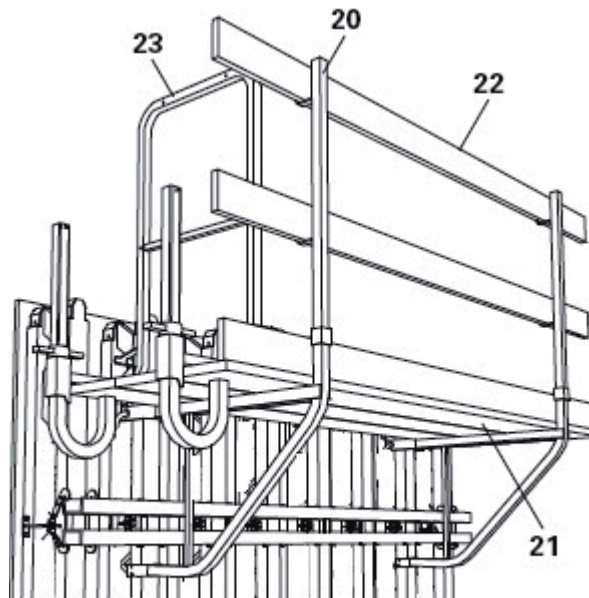
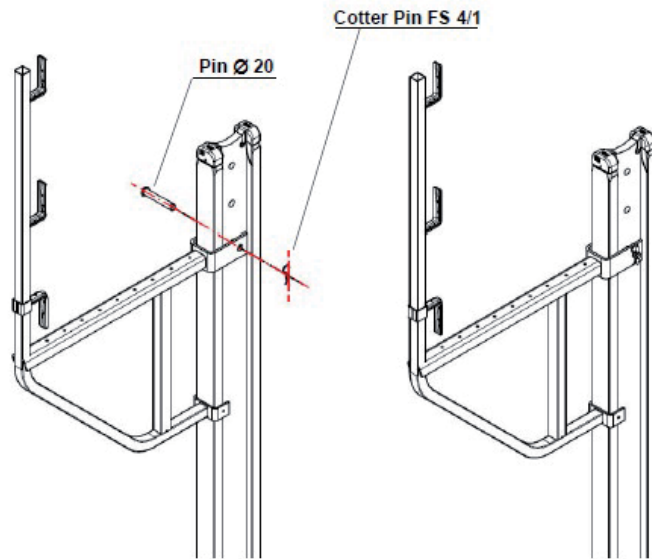

Fig.B2.01.1



Fig.B2.01.2

B3 Crane Lifting Unit, lifting by crane

Crane Splice-2 VT 20



Follow Instructions for Use.
Permissible load bearing capacity
1300 kg.

Assembly

- Remove the 3 nuts and bolts from Crane Splice- 2 VT 20.
- Push Plates over web of the VT 20.
- Insert bolts and tighten all 3 nuts firmly.
- always attach 2 pieces symmetrically to the centre of gravity.
- follow permissible loads as per crane splice table and the accessories-crane eye VT20.

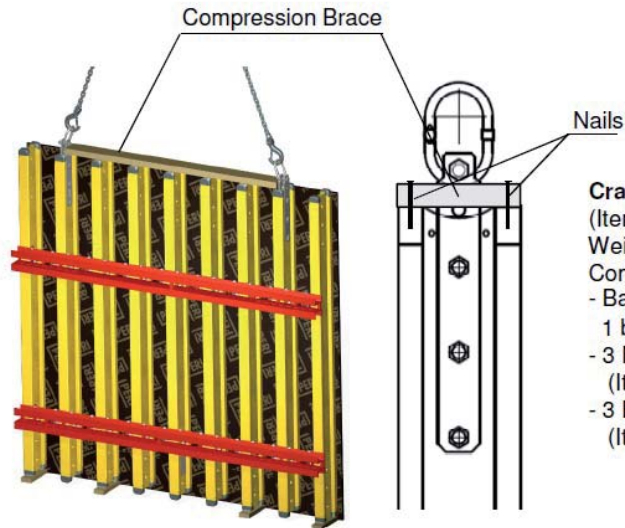

Crane Splice-2 VT 20
 (Item No: 113712)
 Weight 8.1 kg
 Consisting of:
 - Base Unit (2 plates, 1 rivet \varnothing 20,
 1 bolt M20, 1nut M20, 1 crane eye)
 - 3 Nuts M20-8-VZ
 (Item No. 710334)
 - 3 Bolts M20x80-8.8
 (Item No. 024900)

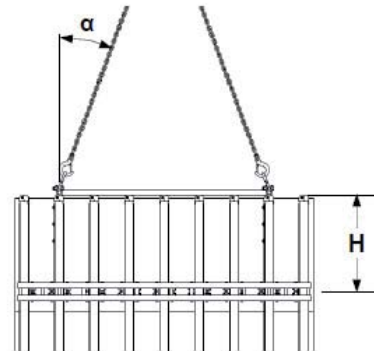

$\alpha \leq 15^\circ$	$15^\circ < \alpha \leq 30^\circ$
<p>Permissible Loads per Crane Splice 1.300 kg for $H < 0.75$ m 1.000 kg for $0.75 \text{ m} < H < 1.00$ m 0 kg for $H > 1.00$ m No Compression Brace necessary</p>	<p>Permissible Load per Crane Splice 1.300 kg. As Compression Brace a board $\geq 45 \times 200$ mm has to be used. Nail to girder chords by means of nails 3.1 x 90 mm. Press Compression Brace tightly towards the Crane Splices.</p>



B4 External Corners

With Outside Corner Coupling AKZ 85/85

Installation

The external corner is formed using two VARIO panels $b = 250$ cm.
 Panel ① with Outside Corner Coupling AKZ,
 Panel ② without coupling.

1. Insert Outside Corner Coupling AKZ (40) into the steel waler of the non-movable element.
(Fig. B4.01)
2. Clamp outside corner coupling in position with Wedge KZ (41b) = first longitudinal hole in the coupling and sixth longitudinal hole in the steel waler.
3. Insert second Wedge KZ (41a) as securing wedge into the steel waler.
(Fig. B4.01)



Mount Outside Corner Coupling AKZ on horizontally-positioned element from top to bottom.

Erection

1. Position element with outside corner coupling and secure.
2. Position second element and adjust to suit wall thickness.
3. Remove KZ securing wedge (41a) and lift Wedge KZ (41b).
(Fig. B4.03)
4. Swivel outside corner couplings one after the other into the steel waler and tightly connect (tension and compression) by means of the Wedge KZ (41).
(Fig. B4.04)

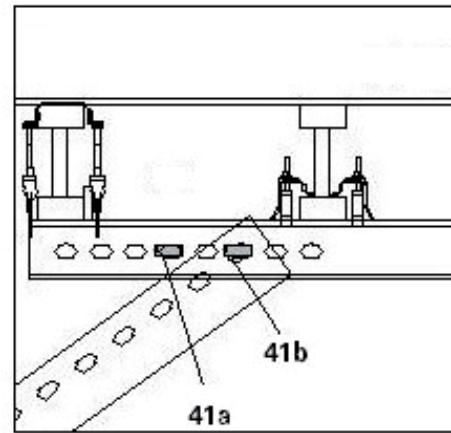
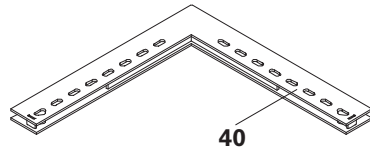

Fig. B4.01

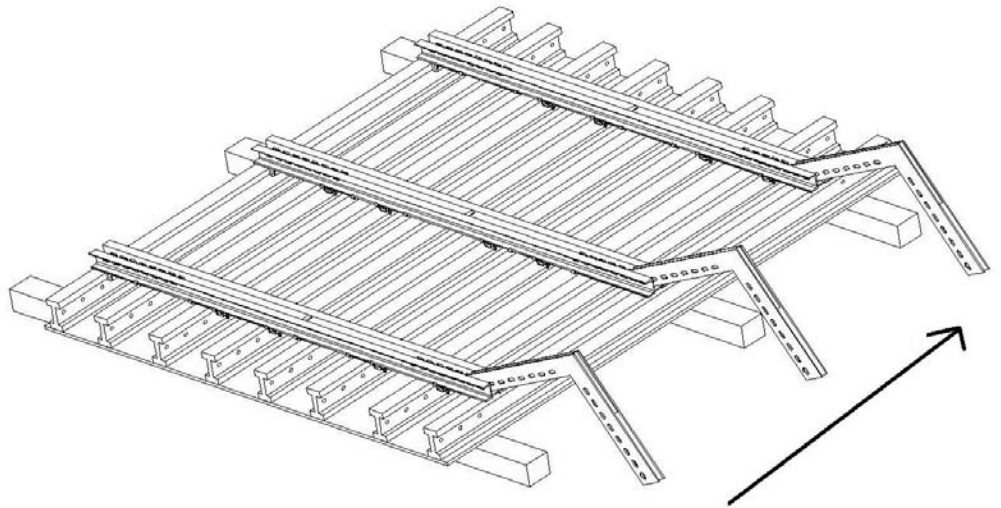

Fig. B4.02

Fig. B4.03

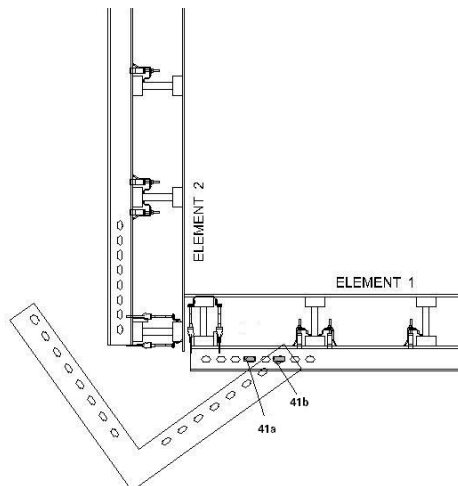
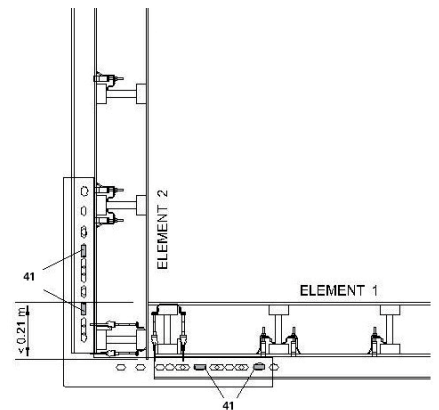

Fig. B4.04



B4 External Corners

With Outside Corner Tie Yoke SKZ

Installation

The external corner is formed using two VARIO panels connected with outside corner coupling Tie Yoke SKZ (1) for tensioning external corner with Steel Waler SRZ,SRU.

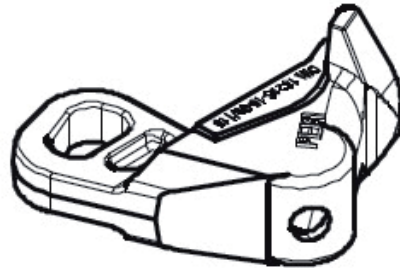

Fig. B4.05

1. Attach Tie Yoke SKZ (1) on both sides to restrain the outside corner pannels assembled ,using a hammer and a tension proof wedge. (Fig. B4.05)
2. Insert threaded Tie rod through SKZ yoke (1), and secure with wingnuts.
3. Wingnuts are tied to complete operation .
4. Hammer tension proof wedge in again firmly, this will lead to a tighter joint connection. (Fig. B4.06)



Mount Outside Stop board (2) at edge girder to one of the panel from top to bottom.

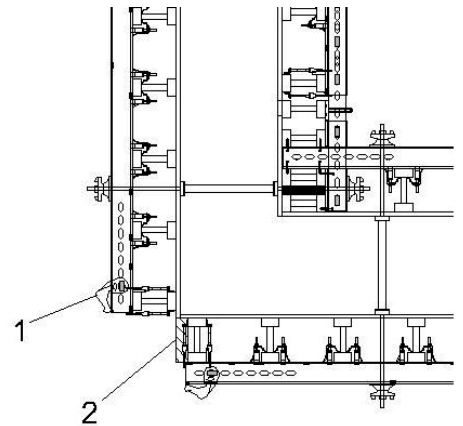
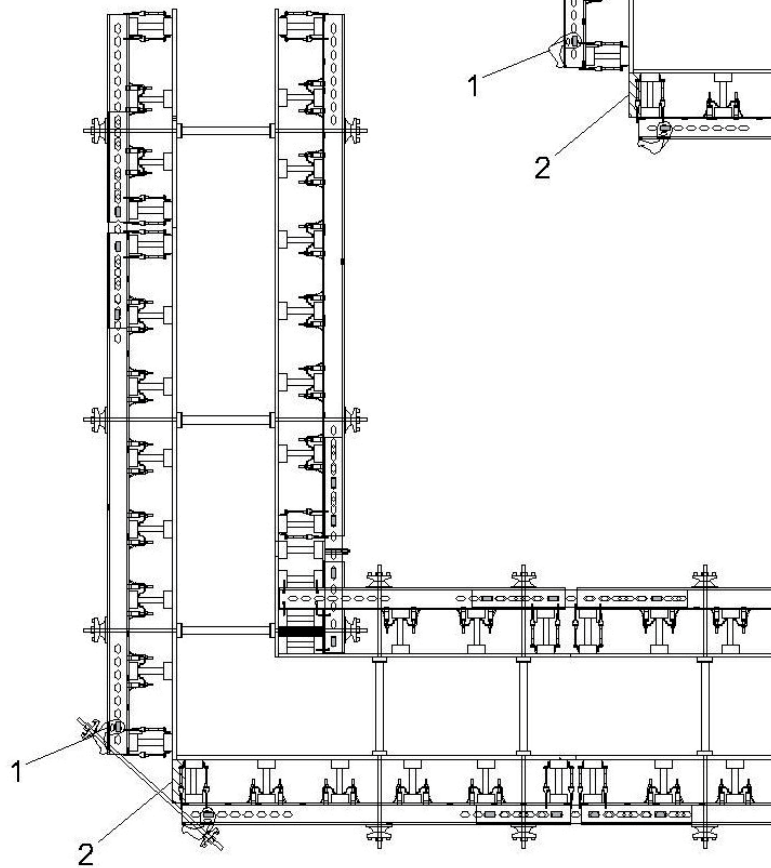

Fig. B4.06



B5 Internal Corners

With VARIO Steel Waler VSRZ

Installation

- Always begin in a corner!
 Check if it is the right or left corner!
1. Support element.
 2. Mount filler element according to the position of the wall element: see A3 Assembly of Internal Corner with VSRZ.
 3. Install ties according to plan.



NB: mounting positions of steel waler and filler element.
 Element with Steel Waler VSRZ (42b) and filler element.
 Corner right = Fig. B5.01
 Corner left = Fig. B5.02

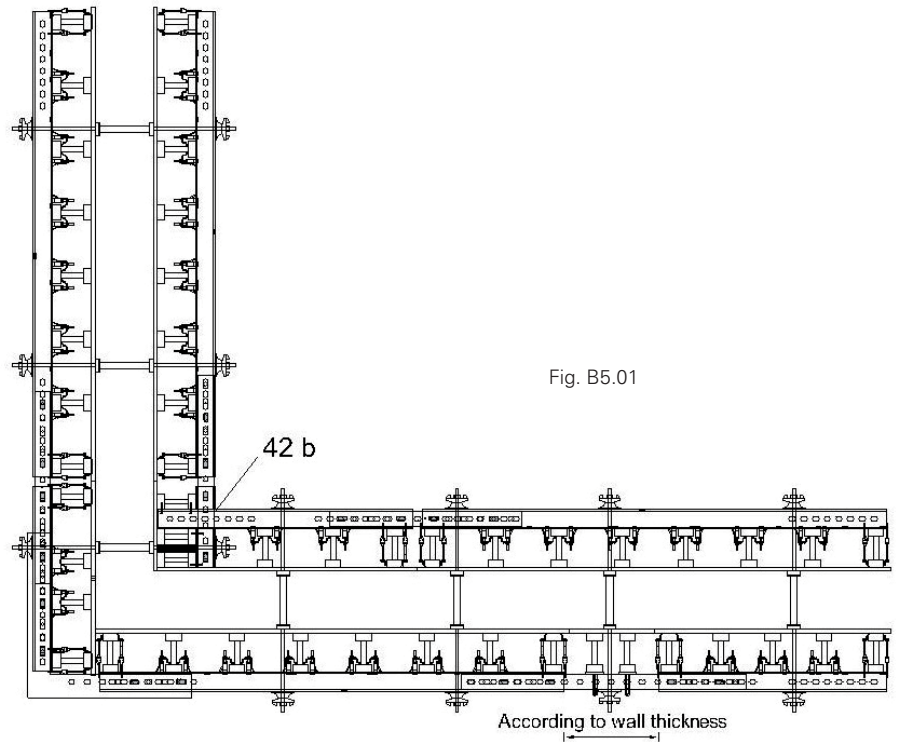

Fig. B5.01

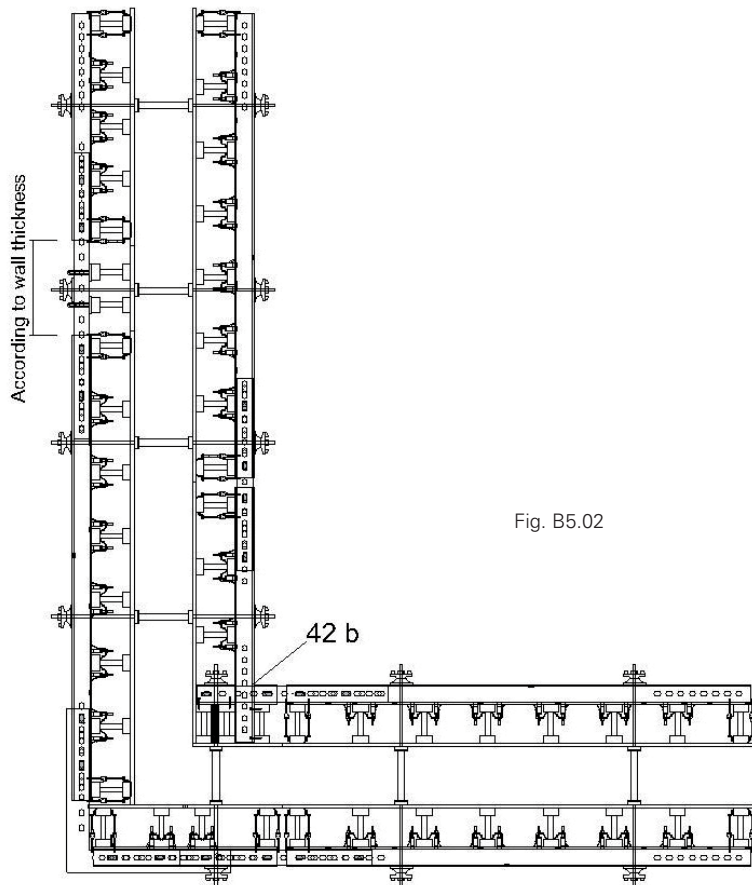
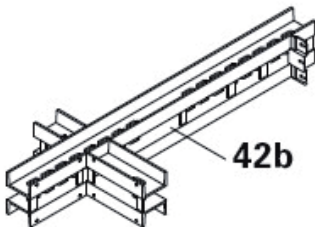

Fig. B5.02

B5 Internal Corners

With Internal Corner Waler TKZ

Installation

The internal corner is formed using two VARIO panels (element 1 and element 2) with corner coupling TKZ(70a). Element 1 shows assembly of standard panel bonded with additional perpendicular plywood panel supported by solid timber with TSS-Torx 6x80, and additional VT20 girder with KDP plate.

1. Mount element 1 supported by Push-Pull Props and Kicker Braces in vertical position. (Fig.B5.03)
2. Insert internal corner coupling TKZ (70a) perpendicularly to SRZ Waler of element 1, and clamp it in position with KZ wedges. (Fig.B5.04)
3. Mount element 2 supported by Push-Pull Props and Kicker Braces perpendicular to element 1 and having a minimum distance 10 cm between SRZ Walers. (Fig.B5.05)
4. Clamp TKZ in position with element 2 by KZ wedge. (Fig.B5.06)
5. Secure the K wedges of the coupling compression plate once fixing all the items. (Fig.B5.07)

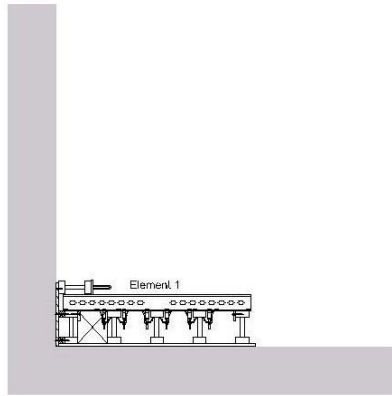

Fig. B5.03

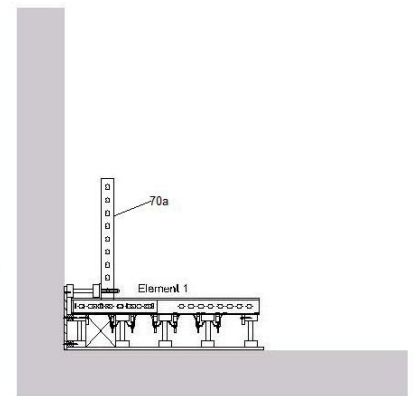

Fig. B5.04

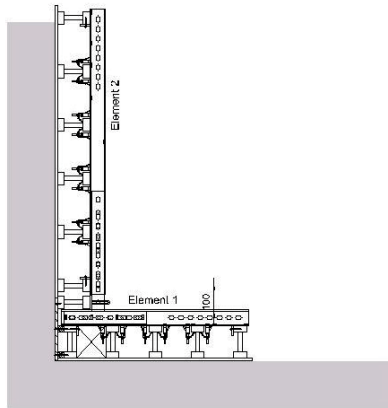

Fig. B5.05

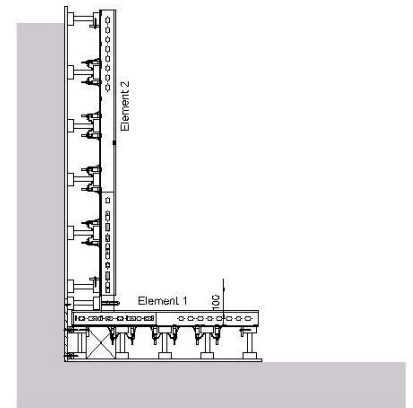

Fig. B5.06

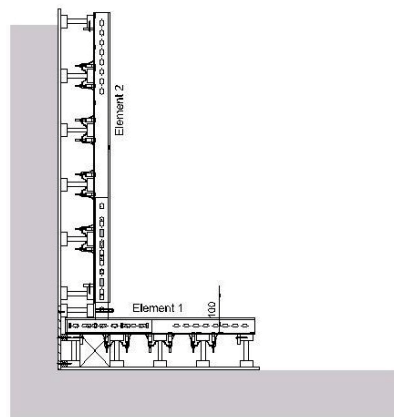
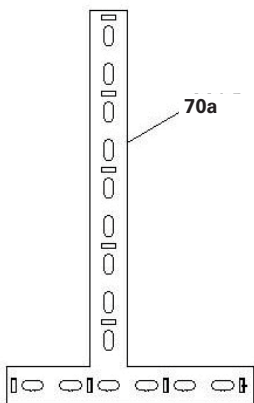
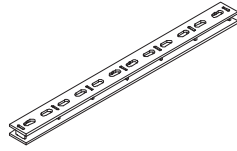

Fig. B5.07

B6 Element Connections

Element coupling with Coupling VKZ 99

Element connections are formed with Coupling VKZ 99 (11) and four Wedges KZ (41).



The direction of the wedge tip shows whether the wedge pulls or pushes.

Wedge tip points to the element joint (a)
= wedge pulls

Wedge tip points away from the element joint (b)
= wedge pushes

(Fig. B6.01)

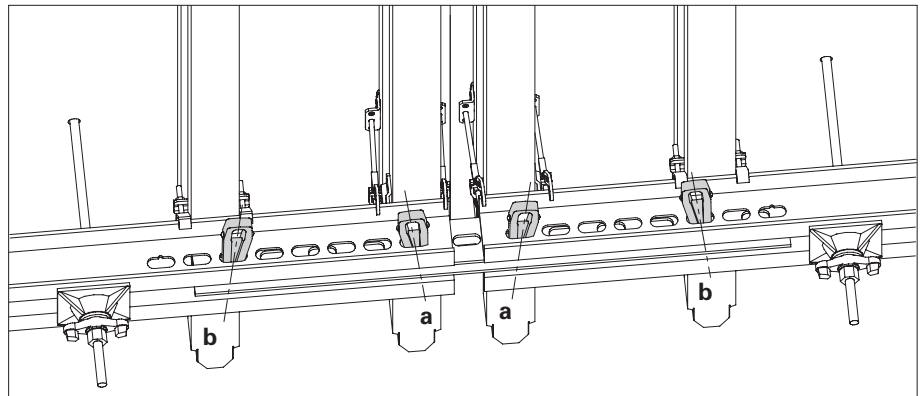
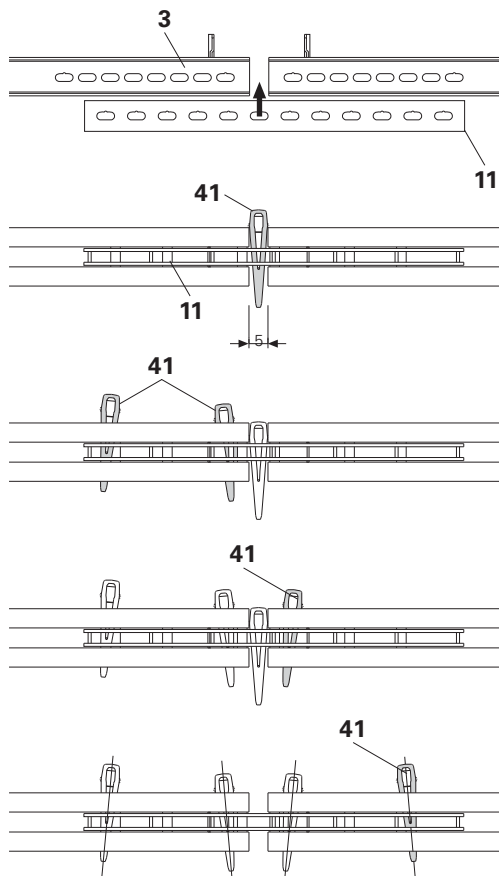

Fig. B6.01

Installation

The coupling is fitted so that the cut-outs point toward the concreting side. This results in a flush element joint.



1. Centrally-position the coupling (11) between the steel walers and centre (Steel Waler SRZ) with Wedge KZ (41).

2. Hammer in second Wedge KZ (41) and third Wedge KZ (41) in the first and sixth longitudinal holes respectively.

3. Hammer in fourth Wedge KZ in the first hole on the opposite side.

4. Remove first Wedge KZ (centring wedge) and hammer in the sixth hole.



An even number of holes (four) must be left between the wedges!

B7 Length Compensations

Length compensation with Coupling VKZ 147, VKZ 211

Length compensations are formed with the Coupling VKZ 147 (11.1) and VKZ 211 (11.2) four KZ wedges (41) in each case.

Installation of VKZ 147 and VKZ 211

1. Insert length compensation (10) into the gap.

2. Centrally-position Coupling VKZ.

3. Hammer in tightly two KZ wedges (41) on one side.

Spacing: four holes.

4. Loosely insert two KZ wedges on the other side.

Spacing: four holes.

5. Pull pre-mounted length compensation to the coupling by means of the K wedge (13).

6. Hammer in tightly KZ wedge (41) on the other side.

(Fig. B7.01 + B7.02)

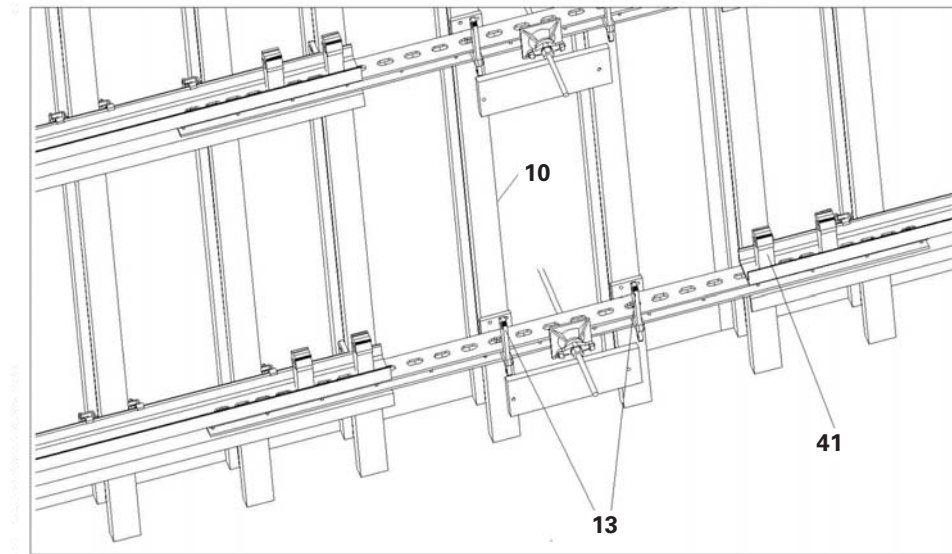
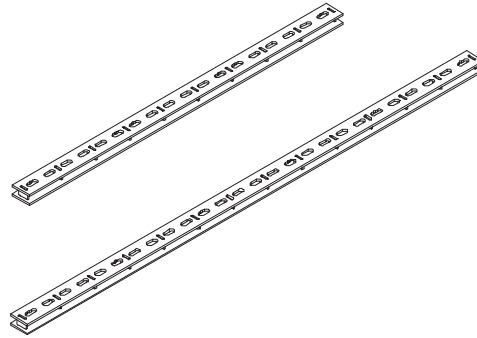

Fig. B7.01

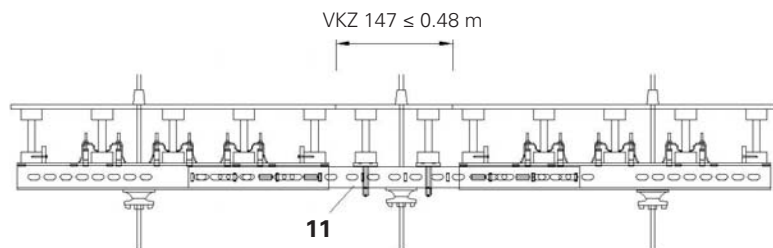
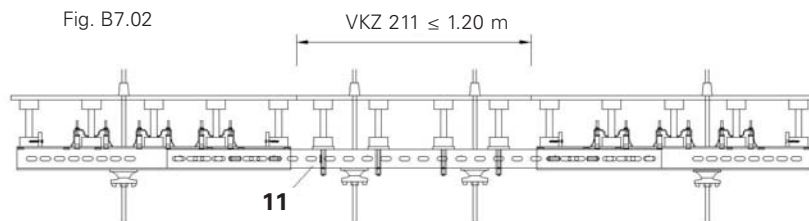

Fig. B7.02



B8 Anchoring

With DW 15, DW 20, DW 26.5 tie systems



Permissible loads:

DW 15 = 90 kN

DW 20 = 150 kN

DW 26.5 = 250 kN



- Do not exceed permissible tie loads.
- Do not exceed the permissible concreting speed.
- Vertical tie spacings conform to water positions and loads.

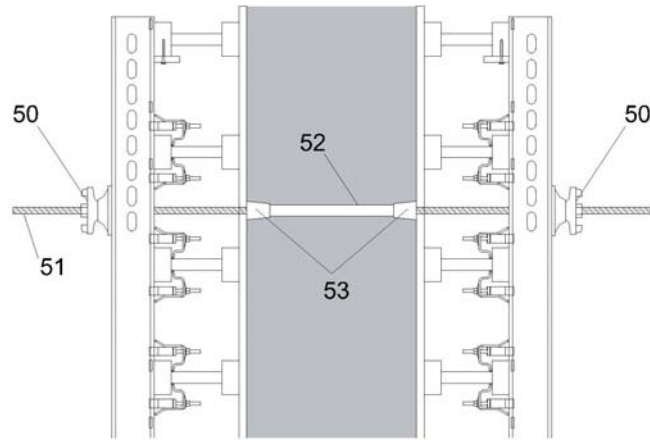

Fig. B8.01

Installation with DW 15

1. Screw on Wingnut Pivot Plate DW 15 (50) to tie rod and insert pre-mounted tie rod (51) from the outside through the primary formwork.
2. Push spacer tube (52) with cone (53) onto the DW 15 tie rod (51).
3. Position closing formwork.
4. Push DW 15 tie rod (51) through the closing formwork and screw on Wingnut Pivot Plate DW 15 (50) and tighten. (Fig. B8.01)

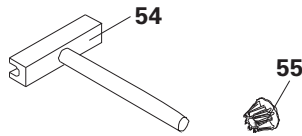

Fig. B8.02

Miscellaneous

- tie rod wrench (54) for tie point operations is used by one worker from one side only
- plugs (55) for closing unused tie holes (Fig. B8.02)
- for special arrangements of tie holes: see PERI Tie Technology brochure.

B9 Stopend Formwork

With Coupling VKZ 99



Permissible tension force 50 kN.

Installation

1. Place prefabricated stopend element against limit plate (57).
2. Mount spacer timber (58) (provided by contractor).
3. Insert Coupling VKZ 99 (11) into the Steel Waler SRZ (3).
4. Fix Coupling VKZ 99 with Wedge KZ (41).
5. Hammer in KZ wedges (41) tightly to fix stopend panel. Pull wedge before push wedge. (Fig. B9.01)

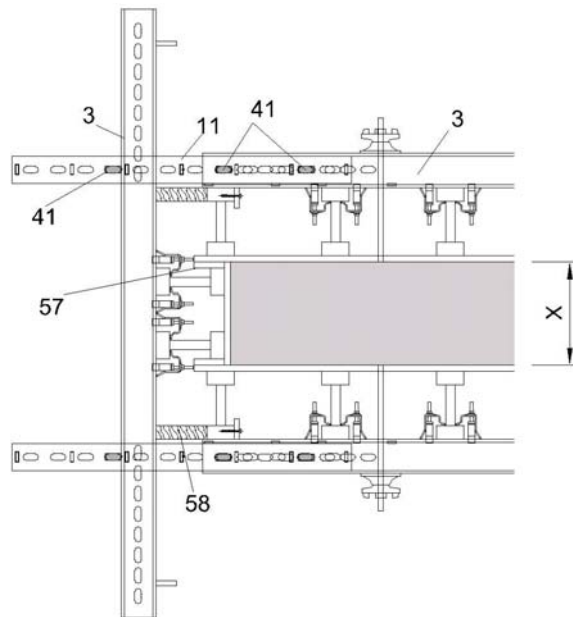

Fig. B9.01

With Stopend Tie



Permissible tension force 30 kN.

Installation

1. Insert stopend tie (56) into the Steel Waler SRZ (3) of the element.
2. Fix stopend tie by hammering in KZ wedges (41) tightly.
3. Screw in tie rod using tie rod wrench up to stopper in threaded sleeve (56.1).
4. Adjust wingnut pivot plate (50.1) accordingly.
5. Place prefabricated stopend element against limit plate (57).
6. Unscrew outside wingnut pivot plate (50.2) and tighten stopend element. (Fig. B9.02)

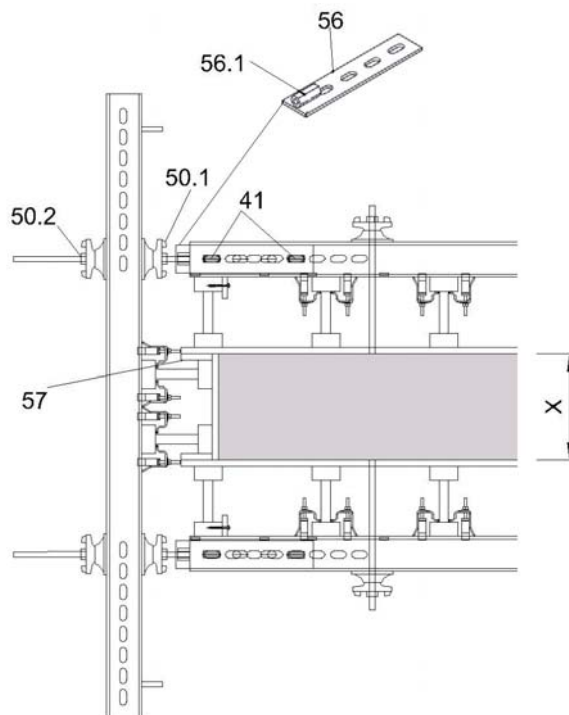

Fig. B9.02

Permissible wind force X for stopend formwork: see PERI Design tables.

B10 Height Extensions

With Extension Splice VT 20 up to a maximum 8.00 m

The required number of Extension Splice 20 depends on the height of the element.

Example; element width 2.50 m

$h < 5.80$ m: 4 extension splices.

(Fig. B10.01)

$h > 5.80$ m: 8 extension splices.

(Fig. B10.02)

Static Values

$$M_{perm.} = 1.30 \text{ kNm}$$

$$Q_{perm.} = 0$$

or

$$M_{perm.} = 0$$

$$Q_{perm.} = 4.60 \text{ kN}$$

$$\frac{M}{0.28} + Q \leq 4.6$$

Static values when moving VARIO VT 20 elements

$$Z_{perm.} = 4.6 \text{ kN}$$

$$M = 0$$

$$Q = 0$$

Assembly on horizontally-positioned element



With extended elements, the Crane Splice VT20 must be mounted on the girders with the Ex-tension Splice VT 20.

1. The gap between 2 girder ends in 2mm.
2. Position splice parts on the right and left of the girder VT 20 web by 2 plates.
3. Connect both parts of the splice and tighten with 6 Bolts M20x80 and 6 Nuts M20-8-VZ.(Fig.B10.03)

The connection is now tight, rigid and flush.

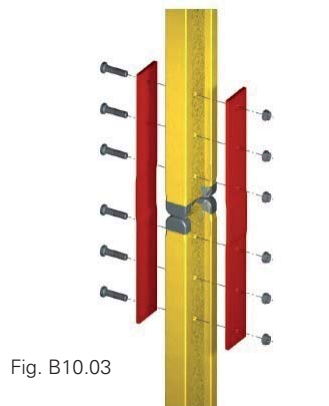

Fig. B10.03

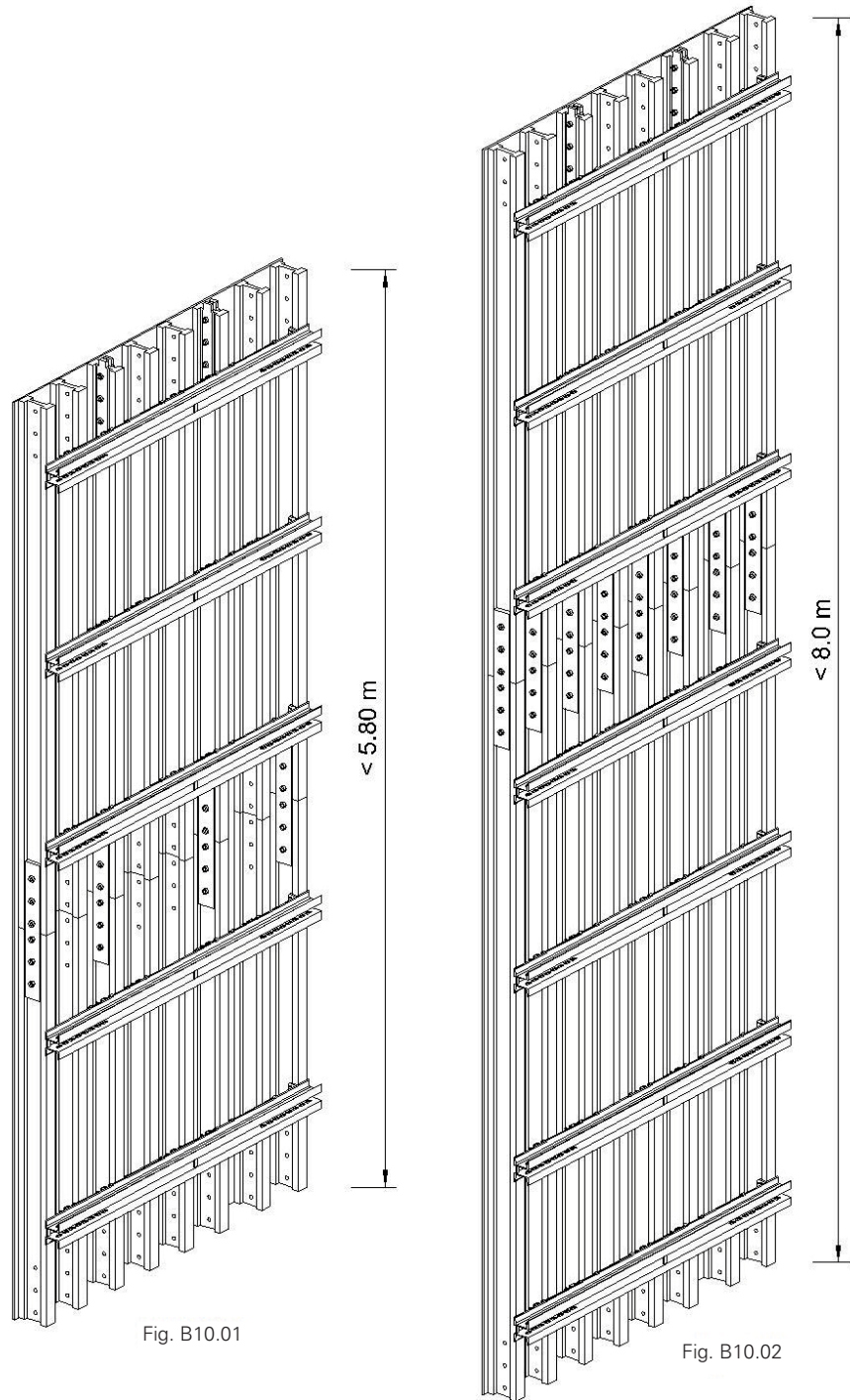

Fig. B10.01

Fig. B10.02

B10 Height Extensions

With overlap girders up to a maximum 11.90 m

The number of girders depends on the element widths and heights: see PERI Design tables.

With overlapped girders (2) for heights of up to 9.80 m. (Fig. B10.04)

With additional overlap girders (2) for heights of up to 11.90 m. (Fig. B10.05)



All extensions must be determined during the planning phase.

Assembly takes place on horizontally-positioned element.

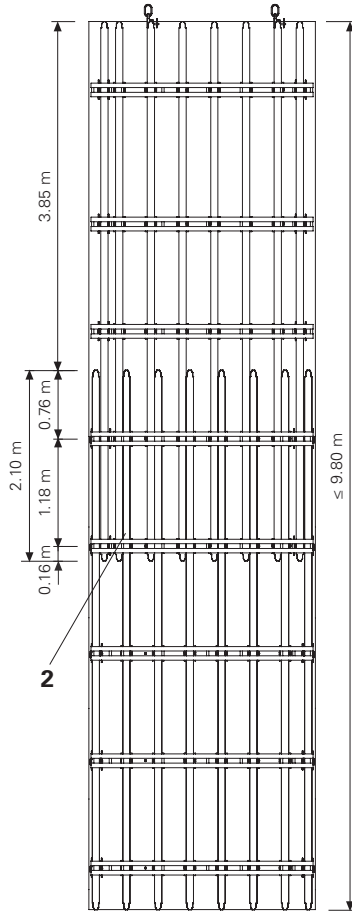

Fig. B10.04

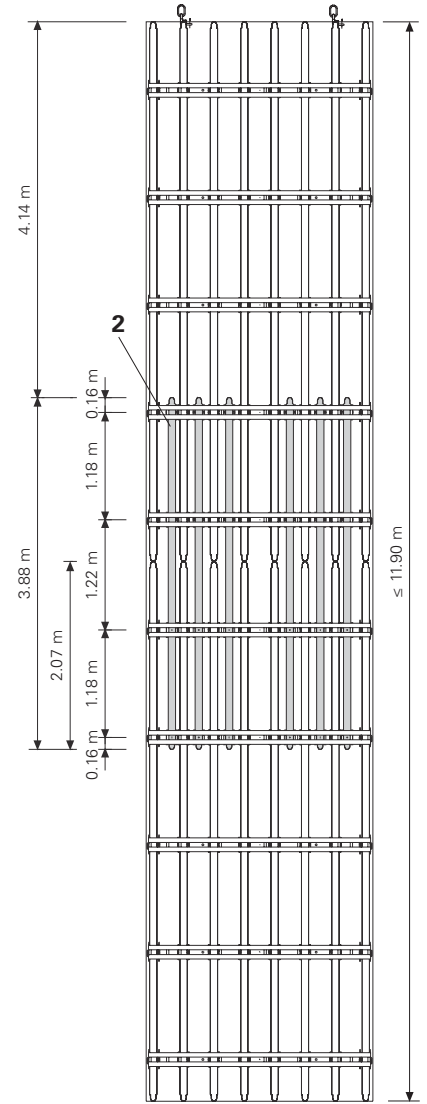

Fig. B10.05

C1 T-Junctions 90°, Obtuse Wall Connection

T-junctions 90°



Depending on the wall thickness, the SRZ or SRU steel walers can be used.
Important:
compensation is always < 25 cm.

With Internal Corner Waler VSRZ

Example with a wall thickness of 30 cm.

Components:

Steel waler SRZ (3).

Internal Corner Waler VSRZ (42).

(Fig. C1.01)

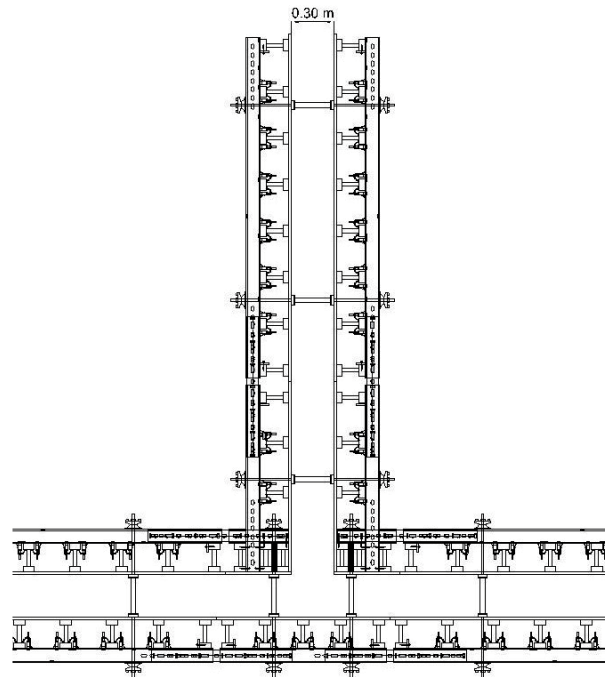

Fig. C1.01

With Internal Corner Waler TKZ

Example with a wall thickness of 30 cm

Components:

Steel Waler SRZ (3).

Internal Corner TKZ (43).

(Fig. C1.02)

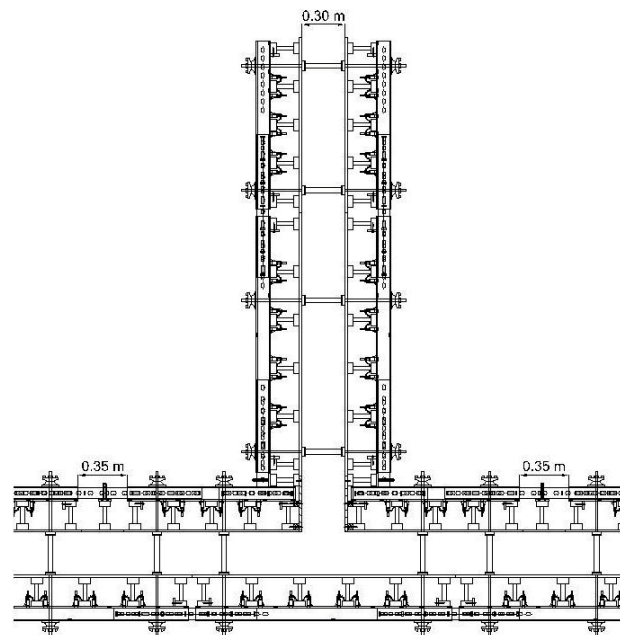

Fig. C1.02

Obtuse wall connection

The tie position is always moved by 62.5 cm.

(Fig. C1.03)

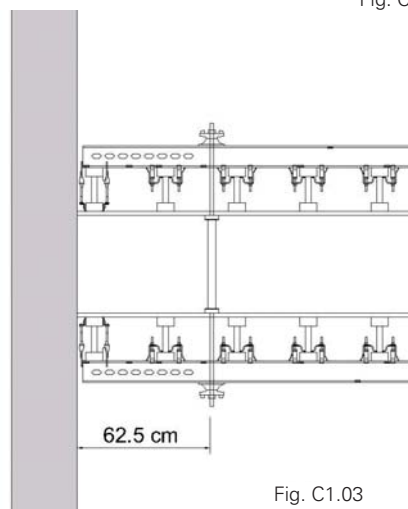

Fig. C1.03

C2 Oblique Angle

Oblique angle with the Articulated Coupling GKZ

With the Articulated Coupling GKZ (43), angles larger than 48° can be continuously formed.

(Fig. C2.01)

The KZ wedge ensures secure and correct mounting as shown in B6.

Utilisation:

- external and internal corners with standard wall thicknesses
- with large wall thicknesses, e.g. bridge construction (Fig. C2.02)
- polygonal circular formwork. (Fig. C2.03)



The larger GKZ 76/76 articulated coupling is normally externally mounted, the smaller GKZ 60/60 articulated coupling on the inside.

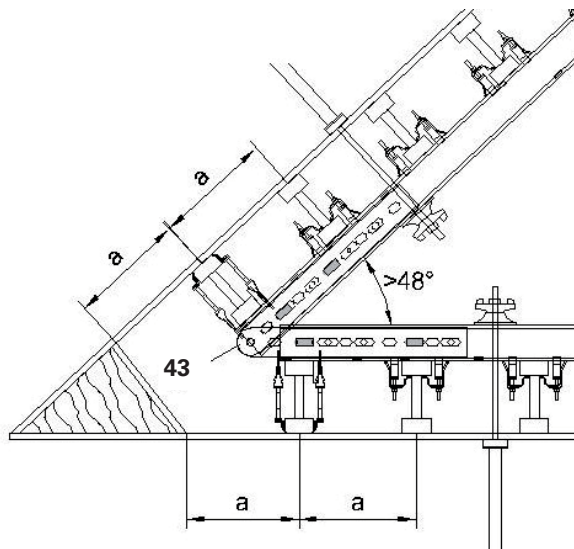

Fig. C2.01

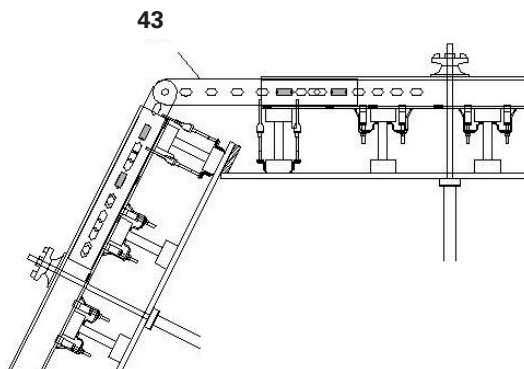

Fig. C2.02

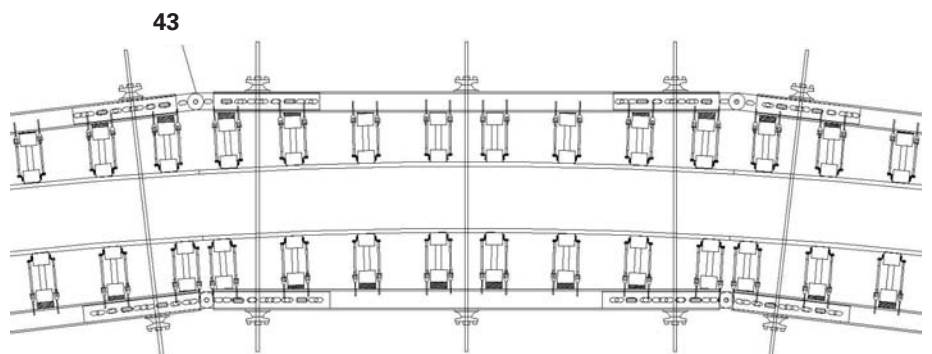

Fig. C2.03

C3 Element Connections for Architectural Concrete

With Coupling VKS 99 Architectural Concrete and Alignment Clamp VRS.



– Compensation up to 5 mm element offsets possible. (Fig. C3.01)

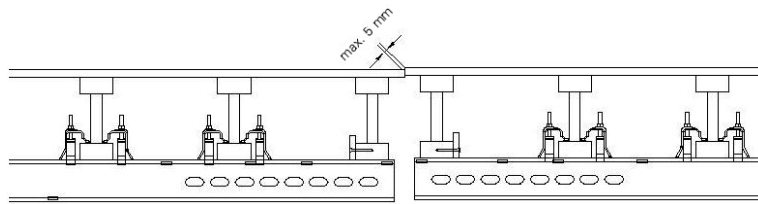
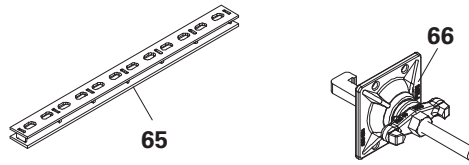
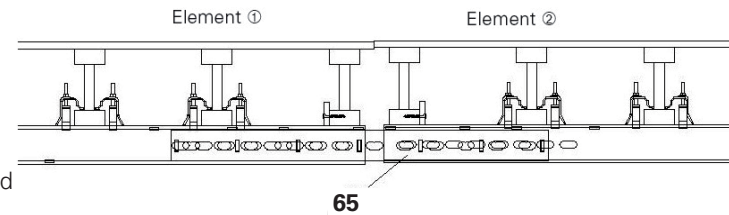

Fig. C3.01

Assembly

1. Centrally position Coupling VKS 99 (65) on the element joint in the steel waler.

The tapering of the trapezoidal-shaped cut-outs point to the concreted side



2. Hammer in the KZ wedge (41) as described in B6.

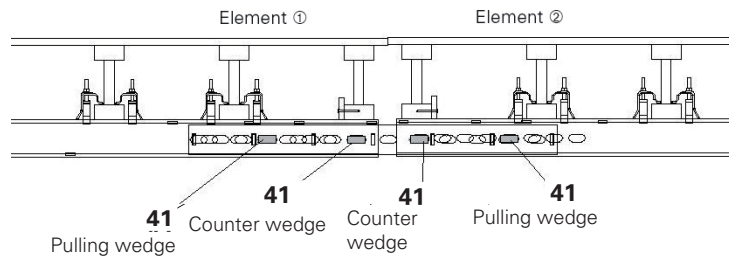

3. Attach one VRS alignment clamp (66) per steel waler to the rear-positioned element in the VKS coupling with spacer. Loosen push-pull wedges on Element ①. If necessary, use counter wedge to slightly open the plywood joint on Element ②.

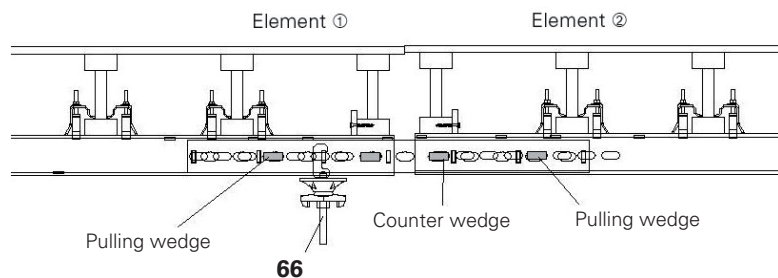

4. Tension the alignment clamp to compensate for the element offset.

Tighten plywood joint on Element ① with the counter wedge and counter with the pulling wedge on Element ①.

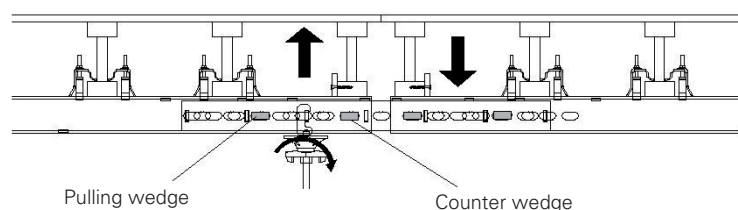

D1 Steel Waler SRU,SRZ

Steel Waler SRU

The SRU steel waler (70) has a wide range of functions and supplements the VARIO system, e.g. in civil engineering or special designs.

Features:

- U120 profile (a)
- no end plate
- lengths up to 6.00 m, 25 cm or 50 cm increments
- with edge beams:
 - no girder claw or HBU, instead notches for securing the HB hook strap (b)
- drilled holes every 12.5 cm along the complete length for various connections, e.g. UK 70 universal coupler (c)
- reinforced spacer only at the front (e) (Fig. D1.01)

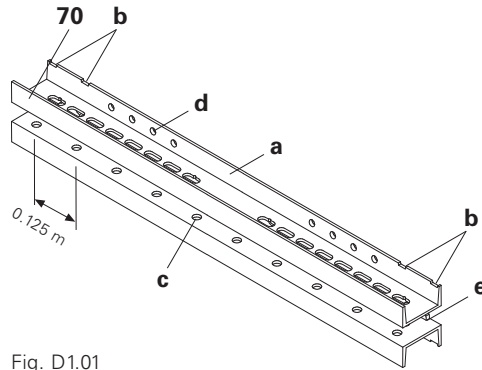

Fig. D1.01

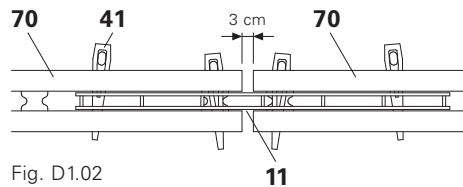

Fig. D1.02

Installation

The cut-outs on the longitudinal holes point towards the concreted side.

SRU/SRU element connection

With Coupling VKZ (11) and Wedge KZ (41).

Spacing between the SRU walers (70) is 3 cm.

(Fig. D1.02)

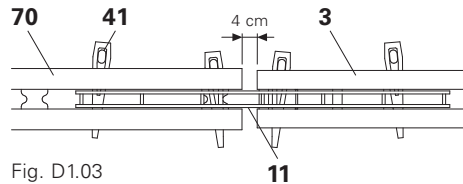

Fig. D1.03

SRU/SRZ element connection

With Coupling VKZ (11) and Wedge KZ (41).

Spacing between the SRU walers (70) and SRZ (3) is 4 cm.

(Fig. D1.03)

D1 Steel Waler SRU,SRZ

Steel Waler SRZ

The SRZ steel waler (70) has a wide range of functions and supplements the VARIO system, e.g. in civil engineering or special designs.

Features:

- U100 profile (a), with optional selection of U120 & U140
- end plates (b)
- variable lengths increments.
- with edge beams fixed with HBU could be connected to the end plate with TSS-Torx 6x60 through the hole found at the end plate.
- reinforced spacer only at the front (c)

(Fig. D1.04)

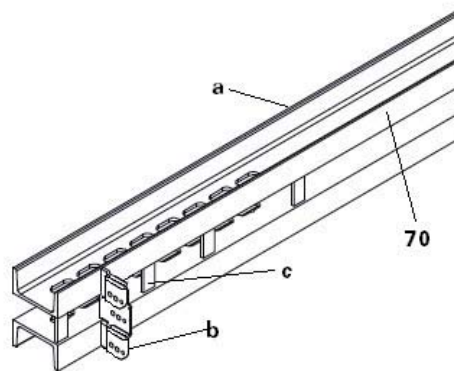

Fig. D1.04

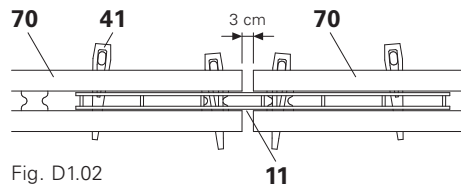

Fig. D1.02

Installation

The cut-outs on the longitudinal holes point towards the concreted side.

SRU/SRU element connection

With Coupling VKZ (11) and Wedge KZ (41).

Spacing between the SRU walers (70) is 3 cm.

(Fig. D1.02)

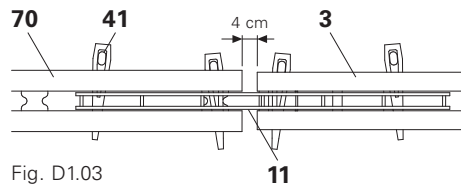

Fig. D1.03

SRU/SRZ element connection

With Coupling VKZ (11) and Wedge KZ (41).

Spacing between the SRU walers (70) and SRZ (3) is 4 cm.

(Fig. D1.03)

D2 Universal Coupling UK 70

Universal Coupling UK 70

- for rigid connections with the SRU waler
- for connecting push-pull props, tie rod cylinder yokes and SLS heavy-duty spindles
- as a fixing point for diagonal bracing. (Fig. D2.01)

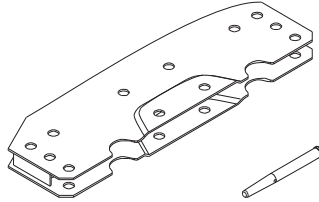

Fig. D2.01

Assembly

The UK 70 universal coupling (75) is fixed using four pins and cotter pins (76). (Fig. D2.02)



The spacing between the two pins must be at least 25 cm.

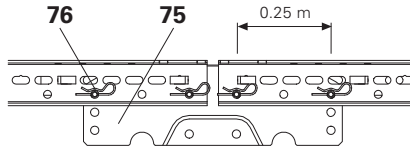

Fig. D2.02

VARIO VT 20 Girder Wall Formwork



Item no. Weight kg

		Girders VT 20K with Steel Cap	L
074990	8,560	Girder VT 20K L = 1.45 m	1445
074905	12,700	Girder VT 20K L = 2.15 m	2150
074910	14,460	Girder VT 20K L = 2.45 m	2450
074890	15,640	Girder VT 20K L = 2.65 m	2650
074920	17,110	Girder VT 20K L = 2.90 m	2900
074930	19,470	Girder VT 20K L = 3.30 m	3290
074940	21,240	Girder VT 20K L = 3.60 m	3590
074950	23,010	Girder VT 20K L = 3.90 m	3890
074960	26,550	Girder VT 20K L = 4.50 m	4490
074970	28,910	Girder VT 20K L = 4.90 m	4900
074980	34,810	Girder VT 20K L = 5.90 m	5900

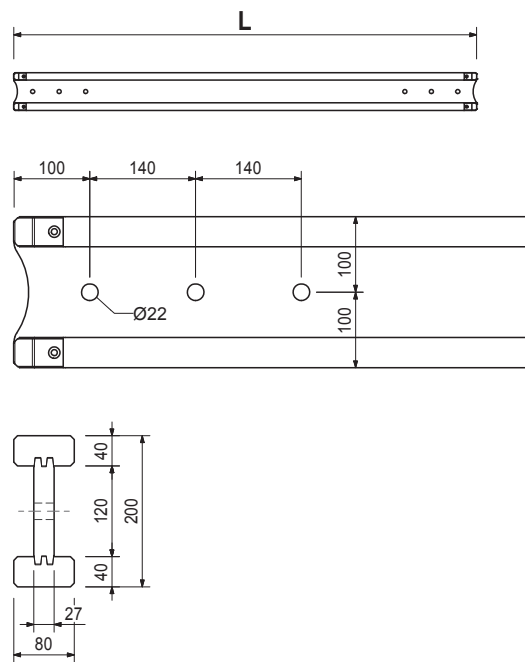
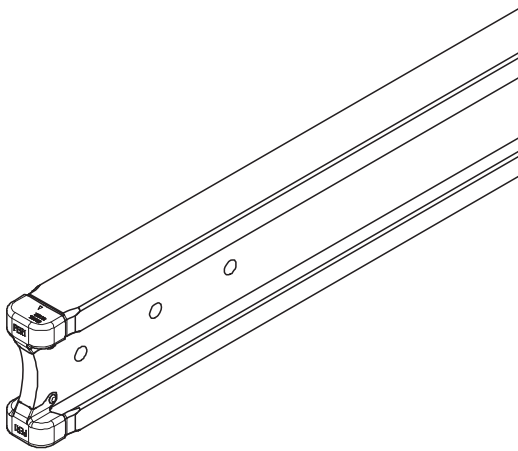

		Girders VT 20 without Steel Cap	L
073710	8,560	Girder VT 20 L = 1.45 m	1445
073720	12,700	Girder VT 20 L = 2.15 m	2150
073730	14,460	Girder VT 20 L = 2.45 m	2450
073740	15,640	Girder VT 20 L = 2.65 m	2650
073750	17,110	Girder VT 20 L = 2.90 m	2900
073760	19,470	Girder VT 20 L = 3.30 m	3290
073770	21,240	Girder VT 20 L = 3.60 m	3590
073780	23,010	Girder VT 20 L = 3.90 m	3890
073790	26,550	Girder VT 20 L = 4.50 m	4490
073800	28,910	Girder VT 20 L = 4.90 m	4900
073810	34,810	Girder VT 20 L = 5.90 m	5900

Item no.	Weight kg
010600	19,800
010030	25,100
010610	30,400
010060	38,300
010070	40,900
010050	51,600
010120	61,500

Steel Waler SRZ U-100 (Metric Length)

	L
Steel Waler SRZ U-100 l = 0.95 m	950
Steel Waler SRZ U-100 l = 1.20 m	1200
Steel Waler SRZ U-100 l = 1.45 m	1450
Steel Waler SRZ U-100 l = 1.825 m	1825
Steel Waler SRZ U-100 l = 1.95 m	1950
Steel Waler SRZ U-100 l = 2.45 m	2450
Steel Waler SRZ U-100 l = 2.95 m	2950

Steel waler for VARIO VT 20 panels and special applications.

Note

Special lengths and other profile sizes on request.

Technical Data

Wy = 82.4 cm³, ly = 412 cm⁴

010360	25,900
010610	30,400
010110	38,100
010370	50,200
010380	75,900
010390	102.00

Steel Waler SRZ U-100 (Imperial Length)

	L
Steel Waler SRZ U-100 l = 1.17 m	1170
Steel Waler SRZ U-100 l = 1.45 m	1450
Steel Waler SRZ U-100 l = 1.78 m	1780
Steel Waler SRZ U-100 l = 2.39 m	2390
Steel Waler SRZ U-100 l = 3.61 m	3610
Steel Waler SRZ U-100 l = 4.83 m	4830

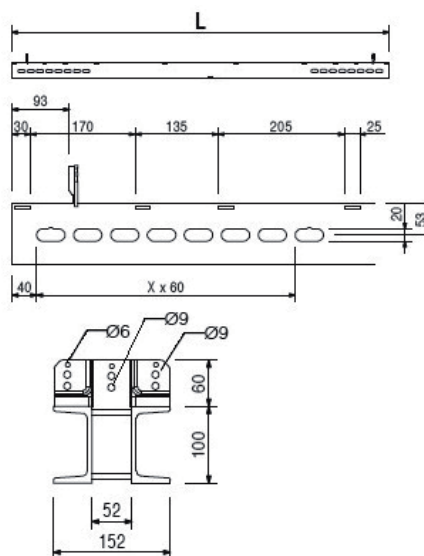
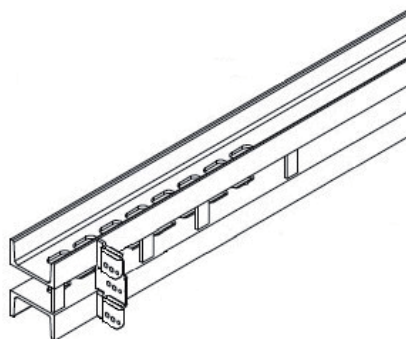

010080	22,000
010150	28,000
010090	33,000
010350	0,000

Steel Waler SRZ Spec. Length
Steel Waler SRZ U-100 Spec. Length
Steel Waler SRZ U-120 Spec. Length
Steel Waler SRZ U-140 Spec. Length
Additional Row of SRZ Slots

Technical Data

Wy = 82.4 cm³, ly = 412 cm⁴

Wy = 121.4 cm³, ly = 728 cm⁴

Wy = 172.8 cm³, ly = 1210 cm⁴

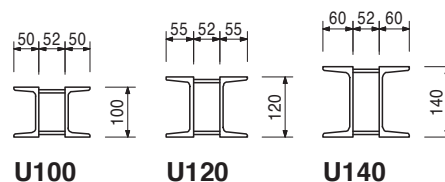

710001	0,376
--------	-------

End Plate SRZ

For Steel waler SRZ with special lengths.

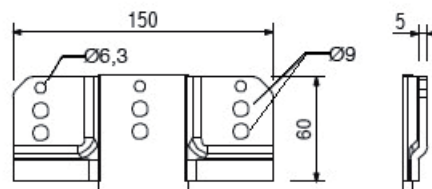
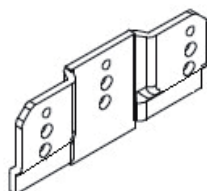

Item no. Weight kg

821901 31,500

Steel Waler VSRZ for VT 20
Steel Waler VSRZ-20 U-100 I = 1.13
 Steel Waler for VARIO VT 20 corner panels and special applications.

Note
 Special lengths and other profile sizes on request.
Technical Data
 $W_y = 82.4 \text{ cm}^3$, $I_y = 412 \text{ cm}^4$

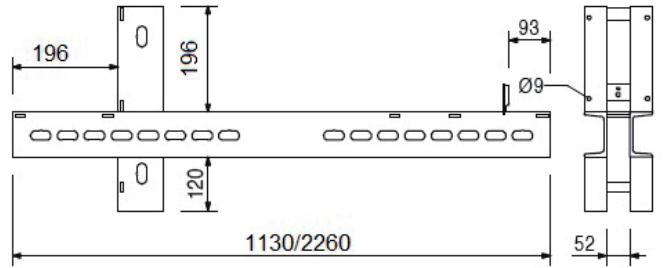
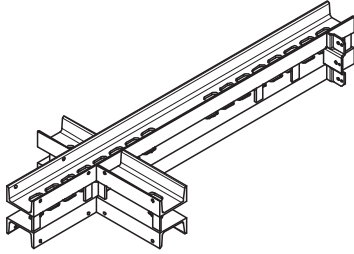

828367 11,500

T Coupling TKZ
 For continuously variable tight (tension and compression) connection of SRZ and SRU steel waler on internal corner.

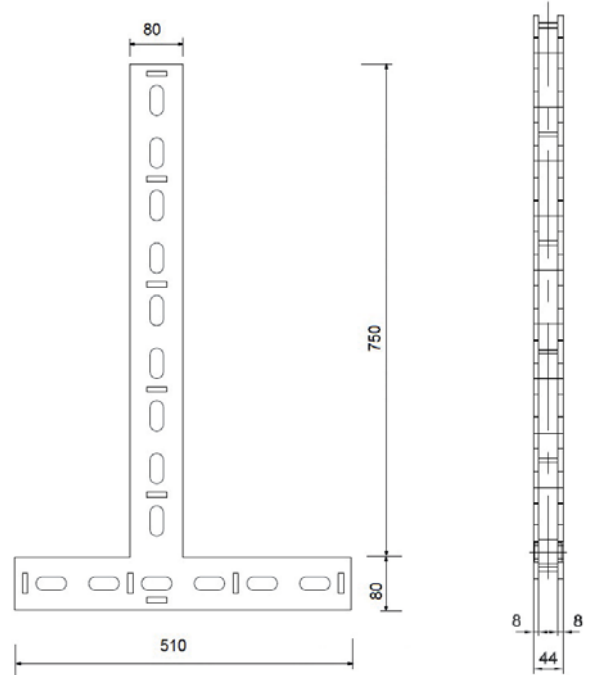
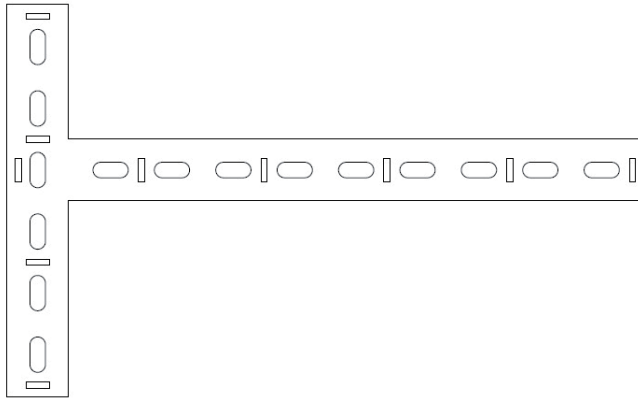

Item no. Weight kg

Item no.	Weight kg	Steel Waler Universal SRU
103868	18,100	Steel Waler Universal SRU U120, l = 0.72 m
103871	24,200	Steel Waler Universal SRU U120, l = 0.97 m
103874	30,900	Steel Waler Universal SRU U120, l = 1.22 m
103877	38,100	Steel Waler Universal SRU U120, l = 1.47 m
103886	44,700	Steel Waler Universal SRU U120, l = 1.72 m
103889	52,000	Steel Waler Universal SRU U120, l = 1.97 m
103898	58,600	Steel Waler Universal SRU U120, l = 2.22 m
103892	65,600	Steel Waler Universal SRU U120, l = 2.47 m
103929	72,000	Steel Waler Universal SRU U120, l = 2.72 m
103903	81,000	Steel Waler Universal SRU U120, l = 2.97 m
103906	92,600	Steel Waler Universal SRU U120, l = 3.47 m
103915	106,000	Steel Waler Universal SRU U120, l = 3.97 m
103918	119,000	Steel Waler Universal SRU U120, l = 4.47 m
103922	135,000	Steel Waler Universal SRU U120, l = 4.97 m
103925	146,000	Steel Waler Universal SRU U120, l = 5.47 m
103928	159,000	Steel Waler Universal SRU U120, l = 5.97 m

Universal steel waler profile U120 used as waling for girder wall formwork and for diverse special applications. With adjustable spacers.

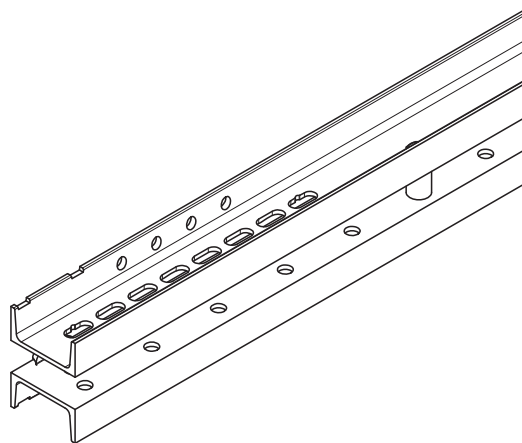

L
722
972
1222
1472
1722
1972
2222
2472
2722
2972
3472
3972
4472
4972
5472
5972

Note
Permissible load: see PERI Design Tables.

Technical Data
U120: $W_y = 121.4 \text{ cm}^3$, $I_y = 728 \text{ cm}^4$.

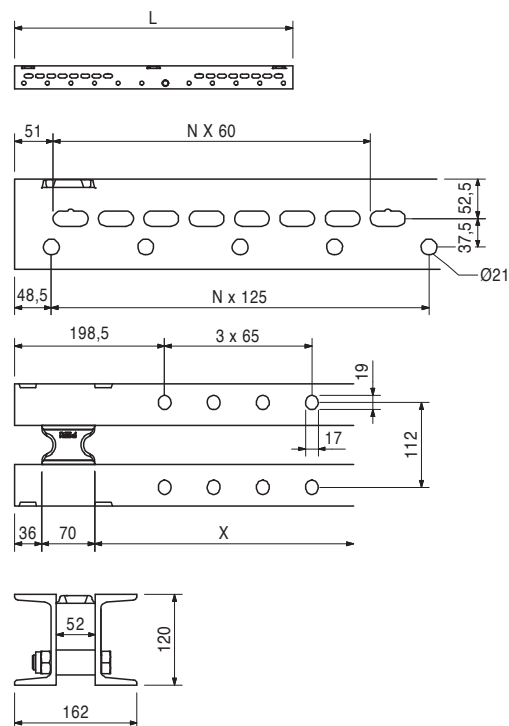

103943	157,000	Steel Waler Universal SRU U140, l = 4.97 m Universal steel waler profile U140 used as waling for girder wall formwork and for diverse special applications. With adjustable spacers.
--------	---------	--

Note
Permissible load: see PERI Design Tables.
Technical Data
U140: $W_y = 172.8 \text{ cm}^3$, $I_y = 1210 \text{ cm}^4$

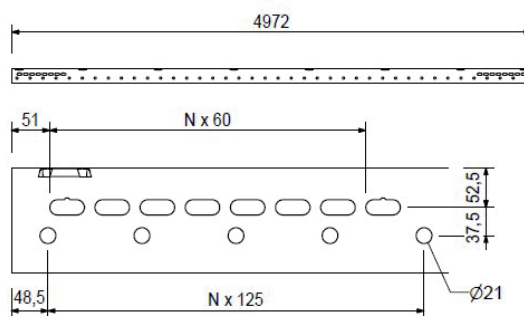
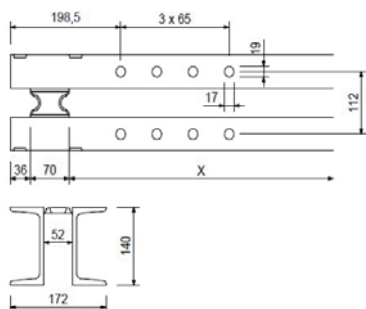

Item no.	Weight kg
024880	0,520

Hook Strap HB for VT.
 For fixing VT 20 Girders to the Steel Waler SRZ or SRU, Profiles U100 – U140.

Note
 The girders can be mounted at right-angles or diagonally to the steel walers.

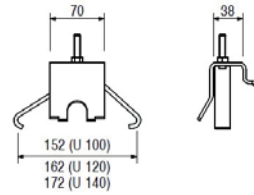
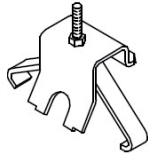

104931	0,865
103845	0,893

Hook Straps Uni HBU
Hook Strap Uni HBU 20-24
Hook Strap Uni HBU 24-28
 For fixing GT 24 Girders or VT 20 Girders to the Steel Waler SRZ or SRU, Profiles U100 – U140.

Note
 The girders can be mounted at right-angles or diagonally to the steel walers and also outside of the nodes.

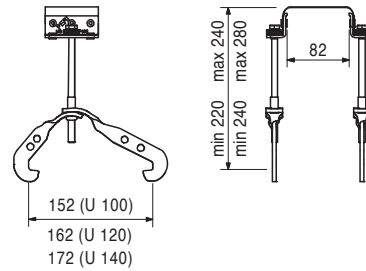
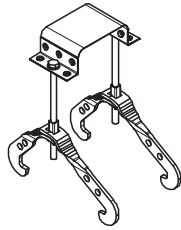

104930	0,887
104096	0,912

Hook Straps Uni Double HBUD
Hook Strap Uni Double HBUD 20-24
Hook Strap Uni Double HBUD 24-28
 For fixing two GT 24 girders or VT 20K girders to SRZ steel walers and SRU Profiles U100 – U140.

Note
 The girders can be mounted at right-angles or diagonally to the steel walers and also outside of the nodes.

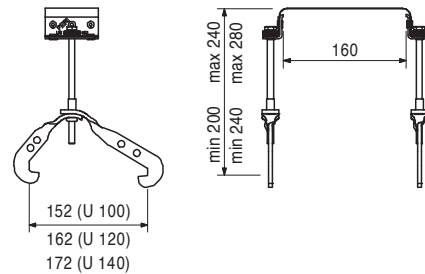
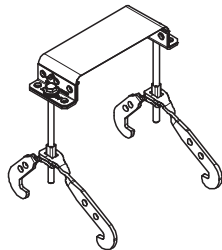

071219	0,000
104929	0,050
107185	0,060
103518	0,060
103844	0,013

Accessories Hook Straps HBU, HBUD
Screw Change HBU, HBUD
Bolt ISO 4014 M8 x 150-8.8, galv.
Bolt ISO 4014 M8 x 180-8.8, galv.
Bolt ISO 4014 M8 x 190-8.8, galv.
Sleeve HBU/HBUD, galv.

Item no. Weight kg

024270	0,023	Lag Screws DIN 571, galv.
024260	0,027	Lag Screw DIN 571 8 x 60, galv.
		Lag Screw DIN 571 8 x 80, galv.

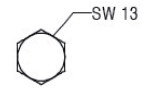
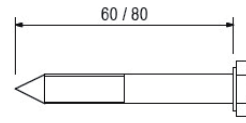
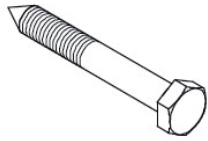

024470	0,008	TSS-Torx, galv.
024690	0,008	TSS-Torx 6 x 60, galv.
		TSS-Torx 6 x 80, galv.
For Torx Blade TX 30. Self-drilling.		

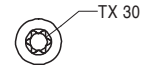
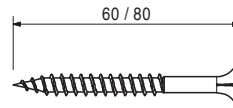
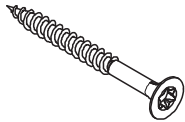

110272	0,006	TSS-Torx 6 x 60, ZKS, galv.
For Torx Blade TX 30. Self-drilling.		

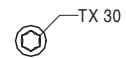
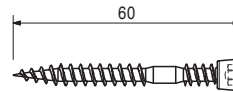
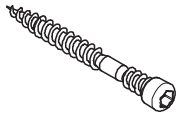

Item no.	Weight kg
128013	2,100

Cordless Combi Drill ABS 18

Universal power screwdriver with continuous electronic speed control and clockwise/anti-clockwise rotation. Including 2 batteries and a battery charger in case.

Note

Follow Instructions for Use!



Accessories

072220	0,400
072140	0,005
128016	0,760

Bit Holder for SCU 7-9

Bit Point TX 30

Replacement Battery Li-Ion 18V

072220	0,400
072140	0,005

Accessories Cordless Combi Drill ABS 18

Bit Holder for SCU 7-9

Bit Point TX 30

128011	1,800
--------	-------

Cordless Impact Screwdriver ASCD 18-W2

Light weight electric power wrench for momentfree working, with clockwise/anti-clockwise rotation and 1/2 square drive. Including 2 batteries and a battery charger in case.

Note

Follow Instructions for Use!



Item no.	Weight kg
128016	0,760

Replacement Battery Li-Ion 18V
 For use with Cordless Combi Drill ABS 18 and Cordless Impact Screwdriver ASCD 18-W2.

Note
 Follow Instructions for Use!
Technical Data
 Capacity 4 Ah.



072180	0,560
--------	-------

Ratchet Wrench 1/2"

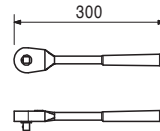
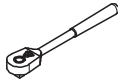

013010	9,000
013020	13,300
013030	19,100
013080	9,000

Couplings VKZ
Coupling VKZ 99
Coupling VKZ 147
Coupling VKZ 211
Coupling VKZ Spec. Length
 For connection of SRZ and SRU steel walers.

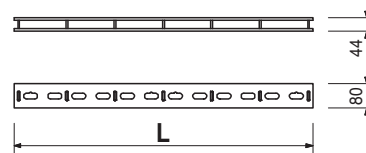
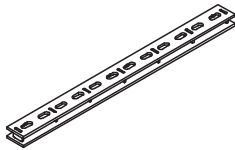

101395	7,110
--------	-------

Offset Coupling VVKZ 3/99
 For connecting extended and non-extended VARIO elements above the extension.

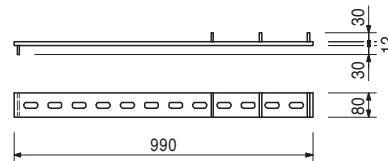
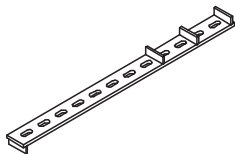

VARIO VT 20 Girder Wall Formwork

Item no.	Weight kg
013140	11,900
013130	13,300
013180	9,000

Corner Couplings EKZ

Corner Coupling EKZ 95/43

Corner Coupling EKZ 76/76

Corner Coupling EKZ Spec. Length

For continuously variable tight (tension and compression) connection of SRZ and SRU steel walers.

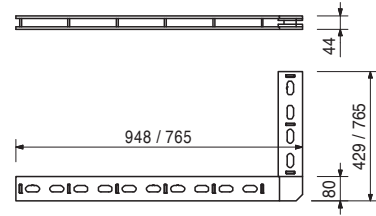
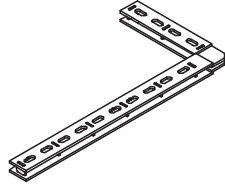

103850	24,700
--------	--------

Outside Corner Coupling AKZ 85/85

For providing tensile and compression-proof connections of Steel Walers SRZ and SRU on external corners.

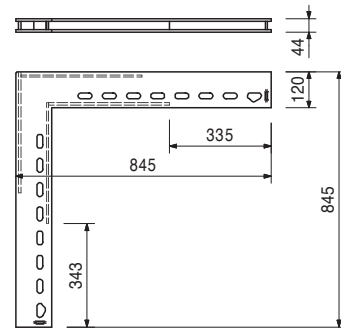
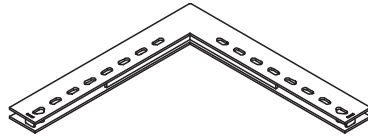

013220	11,500
013210	14,400
013230	9,000

Articulated Couplings GKZ

Articulated Coupling GKZ 60/60

Articulated Coupling GKZ 76/76

Articulated Coupling GKZ Spec. Length

For continuously variable tight (tension and compression) connection of SRZ and SRU steel walers with oblique angles more than 48°.

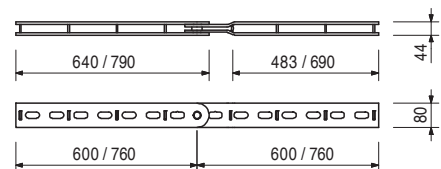
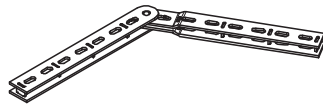

Item no.	Weight kg
102825	8,700

VARIO Coupling Concrete Finish VKS 99
 For connecting VARIO VT20 panels. Allows compensation of up to max. 5 mm panel offsets.

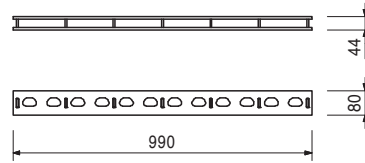
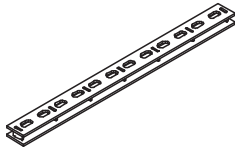

Item no.	Weight kg
102945	2,070

Accessories
VARIO Alignment Clamp VRS

Item no.	Weight kg
103054	11,300

Articulated Coupling GKS 60/60 S
 For connecting VARIO VT20 panels. Allows compensation of up to max. 5 mm panel offsets.

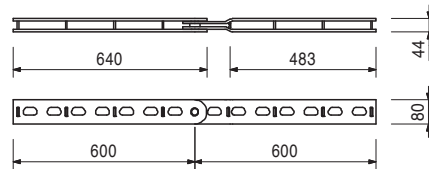
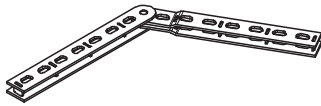

Item no.	Weight kg
102945	2,070

Accessories
VARIO Alignment Clamp VRS

Item no.	Weight kg
102945	2,070

VARIO Alignment Clamp VRS
 In connection with Coupling VKS 99 or Articulated Coupling GKS 60/60. For compensating maximum 5 mm element offset.

Complete with
 1 pc. 030370 Wingnut Pivot Plate DW 15, galv.

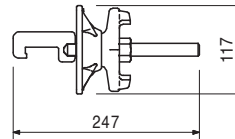
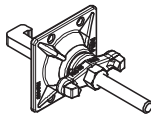

Item no.	Weight kg
103737	10,800

Universal Coupling UK 70
 For a rigid connection of Steel waler SRU and for connecting Heavy-Duty Spindles SLS.

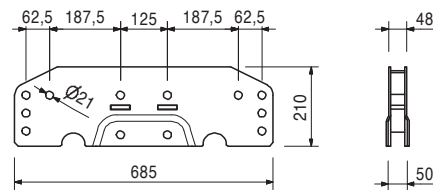
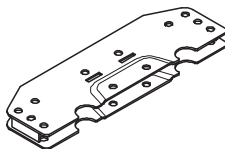

Item no.	Weight kg
104031	0,462
018060	0,030

Accessories
Fitting Pin Ø 21 x 120
Cotter Pin 4/1, galv.

Item no.	Weight kg
104031	0,462

Fitting Pin Ø 21 x 120
For different connections.

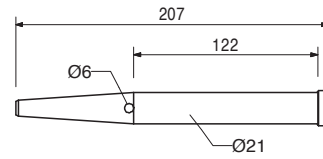
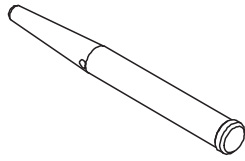

018060	0,030
--------	-------

Accessories
Cotter Pin 4/1, galv.

018060	0,030
--------	-------

Cotter Pin 4/1, galv.



024210	2,180
--------	-------

Tie Yoke SKZ
For tensioning on external corners with Steel Waler SRZ, SRU, U100 - U140 and VARIO couplings.

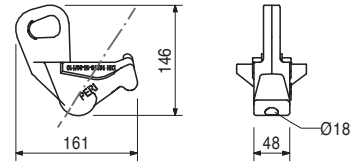

013240	2,100
--------	-------

Stopend Tie
For assembling stopend formwork with VARIO VT 20.

Technical Data
Permissible tension force 30.0 kN.

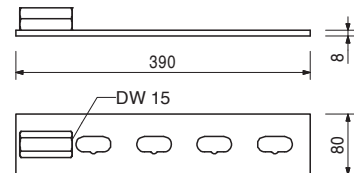
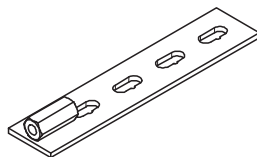

Item no.	Weight kg
024240	0,805

Wedge KZ, galv.
 For connecting panels with VARIO Couplings or Tie Yoke SKZ.

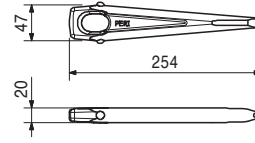

024220	1,230
--------	-------

Coupling Compression Plate KDP
 For mounting girders to VARIO Couplings in infill areas.

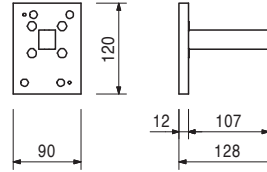
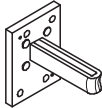

024250	0,331
--------	-------

Wedge K, galv.
 For Coupling Compression Plate KDP, Wedge Head Piece SRZ/SRU and Waler Connector SB-A, B, C.

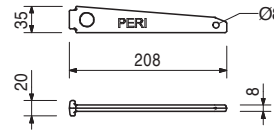

031200	0,470
--------	-------

Chamfer Strip with Flange l = 2.50 m
 Plastic chamfer strip.

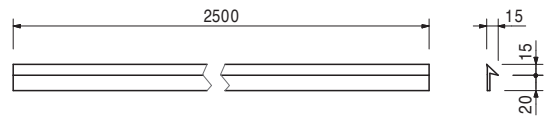
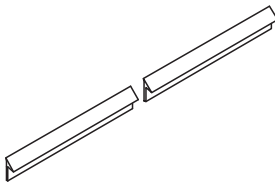

030260	0,500
101706	1,230

Formwork Joints
Formwork Joint 21/20 l = 2.50 m
Formwork Joint 21/40 l = 3.00 m
 Plastic profile strip for easier striking of shafts.

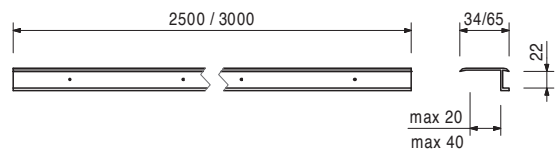
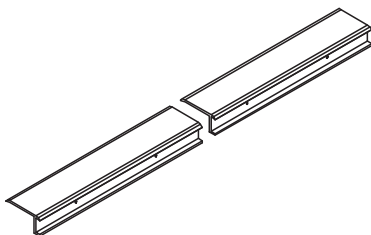

Item no.	Weight kg
028060	1,940

Wedge Headpiece SRZ/SRU

For connecting push-pull props and kicker braces to Steel Waler SRZ and SRU Profile U100 – U140.

Complete with

- 1 pc. 027170 Bolt Ø 16 x 42, galv.
- 1 pc. 018060 Cotter Pin 4/1, galv.

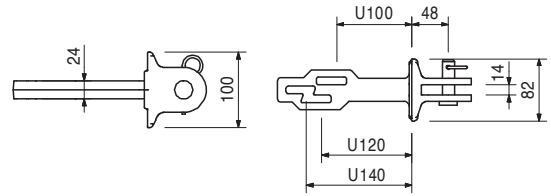
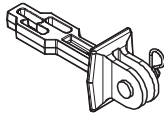

024250	0,331
--------	-------

Accessories

Wedge K, galv.

823419	10,80
--------	-------

Extension Splice VT 20

For extending VT 20 girders and VARIO VT 20 elements up to max. height of 8.00 m.

Complete with

- 2 Plates
- 6 pc. 024900 Bolt M20x80-8.8
- 6 pc. 710334 Nuts M20-8-VZ

Technical Data

Refer to permissible load page xx

Safety Instructions

All girders of the panel have to be connected and never exceed the permissible loads. Follow Instructions of use at all times.

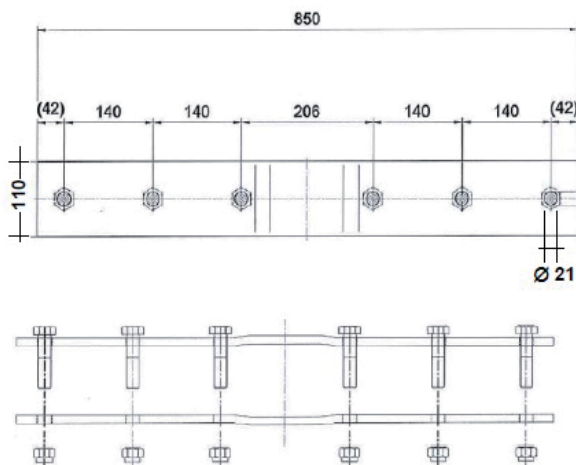
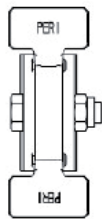

Item no.	Weight kg
113712	8,10

Crane Splice VT 20

For transporting elements by crane with the VT 20 Girder

Complete with

3 pc. 024900 Bolt M20x80-8.8
3 pc. 710334 Nuts M20-8-VZ

Technical Data

For Load-carrying capacity, refer to permissible table.

Safety Instructions

Always use 2 pieces per transportation unit.
Follow Instructions of use at all times.

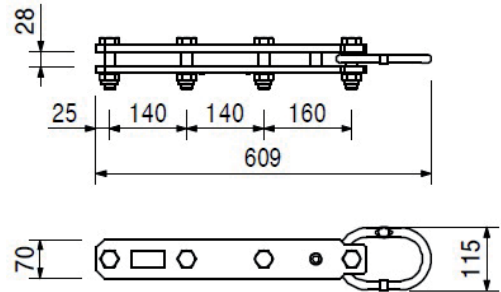

823420	11,20
--------	-------

Scaffold Bracket GB 80-VT

For assembly of a working and concreting scaffold with VARIO VT 20

Technical Data

Permissible load 150 kg/m² with a maximum width of influence 1.25 m.

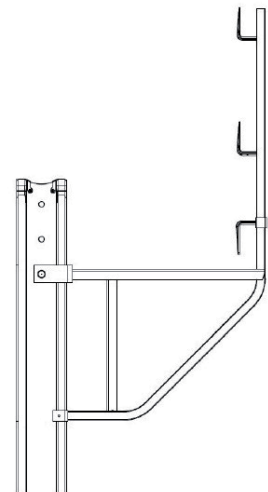
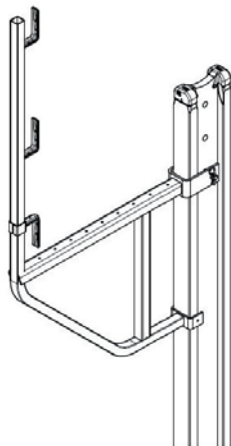

Item no.	Weight kg
107738	24,100

Ladder 240-360
Adjustable from 2.40 m to 3.60 m.

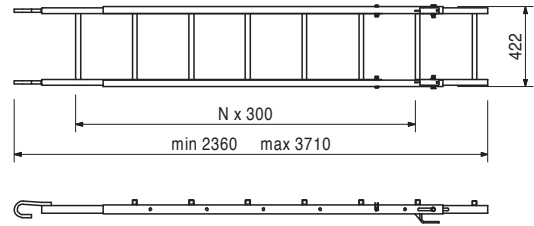
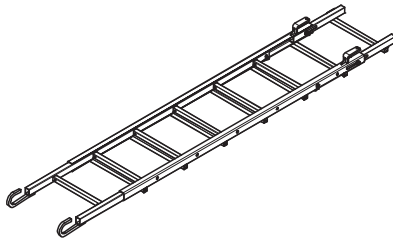

022310	22,000
022320	28,000
022330	33,000
022340	40,000
022350	45,000
022460	0,000

Tunnel Frame Wales RKR
Tunnel Frame Wale RKR U100
Tunnel Frame Wale RKR U120
Tunnel Frame Wale RKR U140
Tunnel Frame Wale RKR U160
Tunnel Frame Wale RKR U180
Welding Unit for RKR

Note
When ordering, please use a copy of the respective version whilst specifying the dimensions. For the wall wales, the VARIO Extension (l= 236 mm) must always be added when determining the total length. Welded joints RKR (1 per wall waler) are to be featured separately.

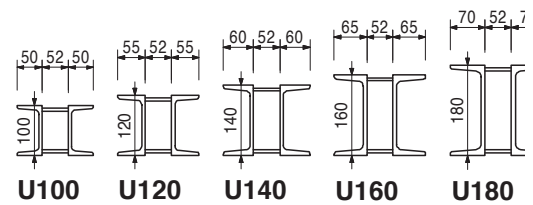

022380	23,500
022440	20,800

Double Spindles RKR
Double Spindle with Wheel RKR
Double Spindle without Wheel RKR

Complete with
 4 pc. 710880 Washer DIN 434 18, galv.
 1 pc. 710252 Bolt ISO 4017 M16 x 50-8.8, galv.
 1 pc. 710229 Nut ISO 4032 M16-8, galv.
Technical Data
 Bearing capacity of Double Spindle 102.5 kN.
 Bearing capacity of Wheel 6.0 kN.

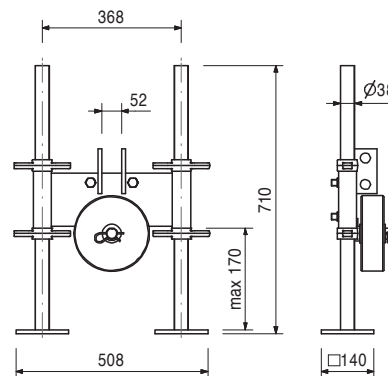
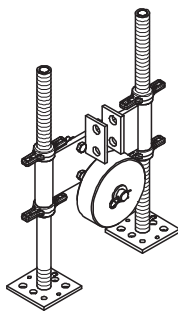

Item no.	Weight kg
022400	12,300

Adjusting Spindle RKR, compl.

For aligning RKR culvert frame formwork. Do not use for transferring loads.

Complete with

2 pc. 725560 Bolt \varnothing 25 x 100
2 pc. 018060 Cotter Pin 4/1, galv.

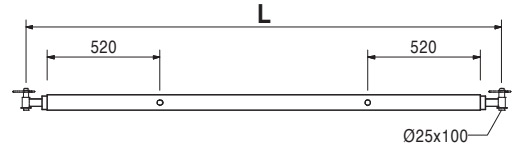
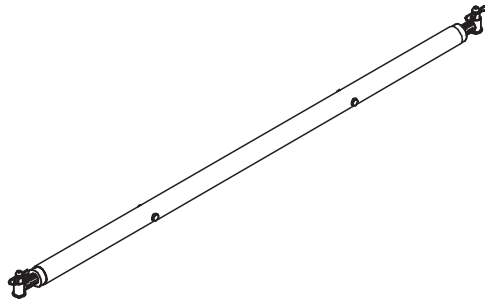

022410	19,600
--------	--------

Corner Spindle RKR

Complete with

10 pc. 710880 Washer DIN 434 18, galv.
10 pc. 710225 Bolt ISO 4017 M16 x 45-8.8, galv.
10 pc. 710229 Nut ISO 4032 M16-8, galv.

Technical Data

Permissible load 90.0 kN.

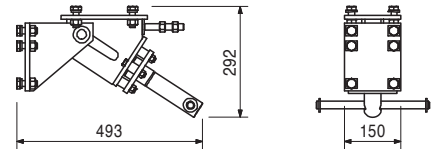
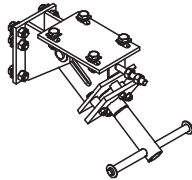

Accessories

701991	0,906
--------	-------

Plate FI 50 x 20 x 120, ESP

701991	0,906
--------	-------

Plate FI 50 x 20 x 120, ESP

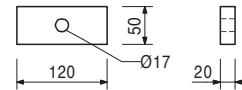

VARIO VT 20 Girder Wall Formwork



Item no.	Weight kg		L
710284	0,031	Bolts ISO 4014-8.8, galv.	
710285	0,050	Bolt ISO 4014 M8 x 60-8.8, galv.	60
722859	0,066	Bolt ISO 4014 M8 x 100-8.8, galv.	100
104929	0,050	Bolt ISO 4014 M8 x 140-8.8, galv.	140
103518	0,060	Bolt ISO 4014 M8 x 150-8.8, galv.	150
710593	0,062	Bolt ISO 4014 M8 x 190-8.8, galv.	190
710242	0,063	Bolt ISO 4014 M10 x 80-8.8, galv.	80
721817	0,040	Bolt ISO 4014 M10 x 100-8.8, galv.	100
710221	0,067	Bolt ISO 4014 M10 x 50-8.8, galv.	50
720610	0,075	Bolt ISO 4014 M12 x 60-8.8, galv.	60
710220	0,087	Bolt ISO 4014 M12 x 70-8.8, galv.	70
750330	0,100	Bolt ISO 4014 M12 x 80-8.8, galv.	80
710299	0,100	Bolt ISO 4014 M12 x 100-8.8, galv.	100
714093	0,123	Bolt ISO 4014 M16 x 60-8.8, galv.	60
710222	0,139	Bolt ISO 4014 M16 x 70-8.8, galv.	70
721729	0,160	Bolt ISO 4014 M16 x 80-8.8, galv.	80
710219	0,170	Bolt ISO 4014 M16 x 90-8.8, galv.	90
710233	0,184	Bolt ISO 4014 M16 x 100-8.8, galv.	100
105402	0,200	Bolt ISO 4014 M16 x 110-8.8, galv.	110
710232	0,200	Bolt ISO 4014 M16 x 120-8.8, galv.	120
722169	0,210	Bolt ISO 4014 M16 x 130-8.8, galv.	130
780155	0,246	Bolt ISO 4014 M16 x 140-8.8, galv.	140
024900	0,278	Bolt ISO 4014 M16 x 160-8.8, galv.	160
710226	0,255	Bolt ISO 4014 M20 x 80-8.8, galv.	80
024910	0,340	Bolt ISO 4014 M20 x 90-8.8, galv.	90
104477	0,303	Bolt ISO 4014 M20 x 100-8.8, galv.	100
711078	0,300	Bolt ISO 4014 M20 x 120-8.8, galv.	120
781054	0,360	Bolt ISO 4014 M20 x 130-8.8, galv.	130
706462	0,447	Bolt ISO 4014 M20 x 160-8.8, galv.	160
109612	0,545	Bolt ISO 4014 M20 x 200-8.8, galv.	200
113686	0,600	Bolt ISO 4014 M24 x 130-8.8, galv.	130
	0,839	Bolt ISO 4014 M24 x 200-8.8, galv.	200

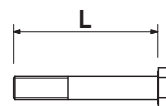
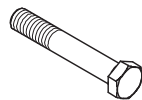

024090	0,005	Nuts ISO 4032, galv.	
710234	0,010	Nuts ISO 4032 M8-8, galv.	
710330	0,017	Nuts ISO 4032 M10-8, galv.	
710229	0,033	Nuts ISO 4032 M12-8, galv.	
710334	0,064	Nuts ISO 4032 M16-8, galv.	
022250	0,100	Nuts ISO 4032 M20-8, galv.	
		Nuts ISO 4032 M24-8, galv.	

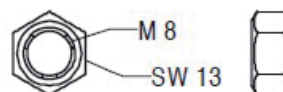



01 Germany
PERI GmbH
 Rudolf-Diesel-Strasse 19
 89264 Weissenhorn
 info@peri.com
 www.peri.com



02 France
 PERI S.A.S.
 77109 Meaux Cedex
 peri.sas@peri.fr
 www.peri.fr

03 Switzerland
 PERI AG
 8472 Ohringen
 info@peri.ch
 www.peri.ch

04 Spain
 PERI S.A.U.
 28110 Algete - Madrid
 info@peri.es
 www.peri.es

05 Belgium/Luxembourg
 N.V. PERI S.A.
 1840 Londerzeel
 info@peri.be
 www.peri.be

06 Netherlands
 PERI Holding B.V.
 5480 AH-Schijndel
 info@peri.nl
 www.peri.nl

07 USA
 PERI Formwork Systems, Inc.
 Elkridge, MD 21075
 info@peri-usa.com
 www.peri-usa.com

08 Indonesia
 PT Beton Perkasa Wijaksana
 Jakarta 10210
 bpw@betonperkasa.com
 www.peri.com

09 Italy
 PERI S.p.A.
 20060 Basiano
 info@peri.it
 www.peri.it

10 Japan
 PERI Japan K.K.
 Tokyo 103-0015
 info@perijapan.jp
 www.perijapan.jp

11 United Kingdom/Ireland
 PERI Ltd.
 Rugby, CV23 0AN
 info@peri.ltd.uk
 www.peri.ltd.uk

12 Turkey
 PERI Kalip ve Iskeleleri Sanayi
 ve Ticaret Ltd.
 Esenyurt / Istanbul 34510
 info@peri.com.tr
 www.peri.com.tr

13 Hungary
 PERI Kft.
 1181 Budapest
 info@peri.hu
 www.peri.hu

14 Malaysia
 PERI Formwork Malaysia Sdn. Bhd.
 43300 Seri Kembangan,
 Selangor Darul Ehsan
 info@perimalaysia.com
 www.perimalaysia.com

15 Singapore
 PERI Asia Pte Ltd
 Singapore 387355
 pha@periasia.com
 www.periasia.com

16 Austria
 PERI Ges.mbh
 3134 Nußdorf ob der Traisen
 office@peri.at
 www.peri.at

17 Czech Republic
 PERI spol. S r.o.
 252 42 Jesenice u Prahy
 info@peri.cz
 www.peri.cz

18 Denmark
 PERI Danmark A/S
 2670 Greve
 peri@peri.dk
 www.peri.dk

19 Finland
 PERI Suomi Ltd. Oy
 05460 Hyvinkää
 info@perisuomi.fi
 www.perisuomi.fi

20 Norway
 PERI Norge AS
 3036 Drammen
 info@peri.no
 www.peri.no

21 Poland
 PERI Polska Sp. z o.o.
 05-860 Płochocin
 info@peri.com.pl
 www.peri.com.pl

22 Sweden
 PERI Sverige AB
 30262 Halmstad
 peri@periform.se
 www.periform.se

23 Korea
 PERI (Korea) Ltd.
 Seoul 06243
 info@perikorea.com
 www.perikorea.com

24 Portugal
 Pericofragens Lda.
 2790-326 Queijas
 info@peri.pt
 www.peri.pt

25 Argentina
 PERI S.A.
 B1625GPA Escobar – Bs. As.
 info@peri.com.ar
 www.peri.com.ar

26 Brazil
 PERI Formas e
 Escoramentos Ltda.
 Vargem Grande Paulista – SP
 info@peribrasil.com.br
 www.peribrasil.com.br

27 Chile
 PERI Chile Ltda.
 Colina, Santiago de Chile
 perichile@peri.cl
 www.peri.cl

28 Romania
 PERI România SRL
 077015 Balotesti
 info@peri.ro
 www.peri.ro

29 Slovenia
 PERI Agency
 2000 Maribor
 peri.slo@triera.net
 www.peri.com

30 Slovakia
 PERI spol. s. r.o.
 903 01 Senec
 info@peri.sk
 www.peri.sk

31 Australia
 PERI Australia Pty. Ltd.
 Glendenning NSW 2761
 info@periaus.com.au
 www.periaus.com.au

32 Estonia
 PERI AS
 76406 Saku vald
 Harjumaa
 peri@peri.ee
 www.peri.ee

33 Greece
 PERI Hellas Solely Owned Ltd.
 194 00 Koropi
 info@perihellas.gr
 www.perihellas.gr

34 Latvia
 PERI SIA
 2118 Salaspils novads, Rigas rajons
 info@peri-latvija.lv
 www.peri-latvija.lv

35 United Arab Emirates
 PERI (L.L.C.)
 Dubai U.A.E.
 perillc@perime.com
 www.perime.com

36 Canada
 PERI Formwork Systems, Inc.
 Bolton, ON – L7E 1K1
 info@peri.ca
 www.peri.ca



- | | | | | |
|---|---|---|--|--|
| <p>37 Lebanon
PERI Lebanon Sarl
90416 – Jdeideh
lebanon@peri.de</p> | <p>44 Russian Federation
OOO PERI
142407, Noginsk District
moscow@peri.ru
www.peri.ru</p> | <p>51 Turkmenistan
PERI Kalıp ve İskeleleri
Aşgabat
ahmet.kadioglu@peri.com.tr
www.peri.com.tr</p> | <p>57 Saudi Arabia
PERI Saudi Arabia Ltd.
21463 Jeddah
info@peri.com.sa
www.peri.com.sa</p> | <p>64 Nigeria
PERI Nigeria Ltd.
Lagos
info@peri.ng
www.peri.ng</p> |
| <p>38 Lithuania
PERI UAB
02300 Vilnius
info@peri.lt
www.peri.lt</p> | <p>45 South Africa
PERI (Pty) Ltd
7600 Stellenbosch
info@peri.co.za
www.peri.co.za</p> | <p>52 Belorussia
IOOO PERI Belarus
220100 Minsk
info@peri.by
www.peri.by</p> | <p>58 Qatar
PERI Qatar LLC
P.O.Box: 31295 - Doha
info@periqatar.com
www.peri.qa</p> | <p>65 Oman
PERI (L.L.C.)
Muscat
perimct@perime.com
www.perime.com</p> |
| <p>39 Morocco
PERI S.A.U.
Tanger
info@peri.ma
www.peri.ma</p> | <p>46 Ukraine
TOW PERI
07400 Brovary
peri@peri.ua
www.peri.ua</p> | <p>53 Croatia
PERI oplate i skele d.o.o.
10 250 Lučko-Zagreb
info@peri.com.hr
www.peri.com.hr</p> | <p>59 Algeria
Sarl PERI
Kouba 16092, Alger
info@peri.com
www.peri.com</p> | <p>66 Colombia
PERI S.A.S. Colombia
Briceño, Cundinamarca
peri.colombia@peri.com.co
www.peri.com.co</p> |
| <p>40 Israel
PERI Formwork
Engineering Ltd.
Rosh Ha'ayin, 48104
info@peri.co.il
www.peri.co.il</p> | <p>47 Egypt
Egypt Branch Office
11341 Nasr City /Cairo
info@peri.com.eg
www.peri.com.eg</p> | <p>54 India
PERI (India) Pvt Ltd
Mumbai – 400064
info@peri.in
www.peri.in</p> | <p>60 Albania
PERI Representative Office
Tirane
info@peri.com.tr
www.peri.com.tr</p> | <p>67 Philippines
PERI-Asia Philippines, INC.
Makati City
info@peri.com.ph
www.peri.com.ph</p> |
| <p>41 Bulgaria
PERI Bulgaria EOOD
1839 Sofia
peri.bulgaria@peri.bg
www.peri.bg</p> | <p>48 Serbia
PERI – Oplate d.o.o.
22310 Šimanovci
office@peri.rs
www.peri.rs</p> | <p>55 Jordan
PERI GmbH - Jordan
11947 Amman
jordan@peri.com
www.peri.com</p> | <p>61 Peru
PERI Peruana S.A.C.
Villa El Salvador, Lima
contacto@peri.com.pe
www.peri.com.pe</p> | <p>68 Hong Kong
PERI (Hong Kong) Limited
Hong Kong SAR, PRC
bob.dover@periasia.com
www.perihk.com</p> |
| <p>42 Iceland
Armar ehf.
220 Hafnarfjörður
armar@armar.is
www.armar.is</p> | <p>49 Mexico
PERI Cimbras y Andamios,
S.A. de C.V.
Estado de México, Huehuetoca
info@peri.com.mx
www.peri.com.mx</p> | <p>56 Kuwait
PERI Kuwait W.L.L.
13011 Kuwait
info@peri.com.kw
www.peri.com.kw</p> | <p>62 Panama
PERI Panama Inc.
0832-00155 Panama City
info@peri.com.pa
www.peri.com.pa</p> | <p>69 Namibia
PERI (Pty.) Ltd.
Windhoek
windhoek@peri.na
www.peri.na</p> |
| <p>43 Kazakhstan
TOO PERI Kazakhstan
050000 Almaty
peri@peri.kz
www.peri.kz</p> | <p>50 Azerbaijan
PERI Representative Office
Baku
peribaku@peri.com.tr
www.peri.com.tr</p> | <p>63 Angola
Pericofragens, Lda.
Luanda
renato.portugal@peri.pt
www.peri.pt</p> | <p>70 Mozambique
PERI (Pty.) Ltd.
Matola
maputo@peri.co.mz
www.peri.co.mz</p> | |

The optimal System for every Project and every Requirements



Wall Formwork



Column Formwork



Slab Formwork



Climbing Systems



Tunnel Formwork



Bridge Formwork



Shoring Systems



Construction Scaffold



Facade Scaffold



Industrial Scaffold



Access



Protection Scaffold

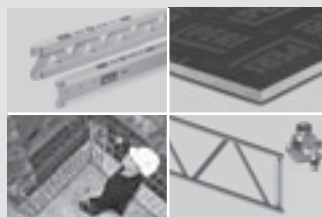

System-Independent Accessories



Services



PERI GmbH
Formwork Scaffolding Engineering
 P.O. Box 1264
 89259 Weissenhorn
 Germany
 Tel. +49 (0)7309.950-0
 Fax +49 (0)7309.951-0
 info@peri.com
 www.peri.com