

# PEP Alpha and PEP Alpha-2 Slab Props

Instructions for Assembly and Use – Standard Configuration – Issue 06/2018



## Main Components

**PEP Alpha**  
all types

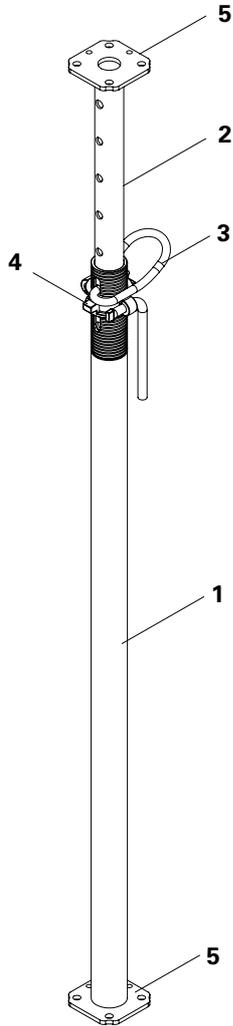

- 1 Outer tube
- 2 Inner tube
- 3 G-hook
- 4 Adjusting nut with grip
- 5 End plates inner tube / outer tube

## Base Plates

**PEP Alpha B**  
(4 holes)

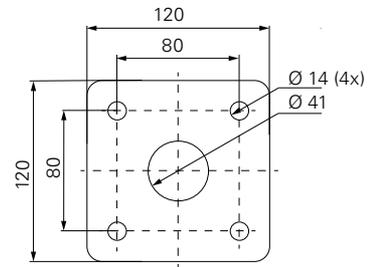

**PEP Alpha D**  
(7 holes)

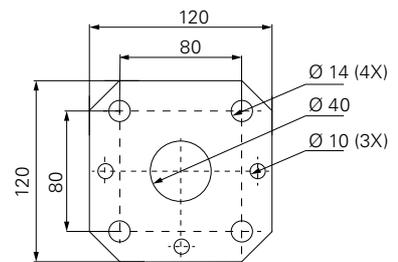

**PEP Alpha - 2**  
all types  
(8 holes)

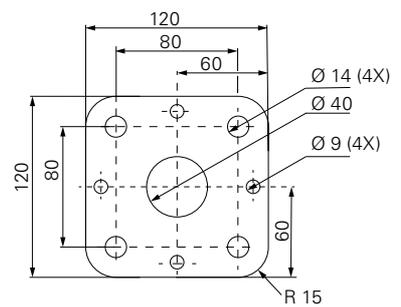

<b>Overview</b>	
Main Components	3
Key	4
Presentational Reference	4
<b>Introduction</b>	
Target Groups	5
Additional Technical Documentation	5
Intended Use	6
Instructions on Use	6
Cleaning and Maintenance Instructions	7
<b>Safety Instructions</b>	
Cross-System	8
System-Specific	9
Storage and Transportation	9
<b>Standard Configuration</b>	
A1 Assembly	
Pre-Assembling the Slab Prop	10
Assembly with Tripod PEP Ergo	11
Assembly with Universal Tripod	12
Assembly with PEP Frame PRK	13
A2 Dismantling	
Releasing the Slab Prop under Load	14
A3 Accessories	
Brace Clamp	15
A4 Foreseeable Misapplications	16
<b>Tables</b>	
Permissible Prop Loads	20
<b>Components</b>	
PEP Alpha Slab Props	22

## Key

### Pictogram | Definition



Safety instructions



Note



Load-bearing point



Visual check



Tip



Misapplication



Safety helmet



Safety shoes



Safety gloves



Safety glasses

### Dimension specifications

Dimensions are usually given in cm. Other measurement units, e.g. m, are shown in the illustrations.

### Conventions

- Instructions are numbered with: 1. ...., 2. ...., 3. ....
- The result of an instruction is shown by: →
- Position numbers are clearly provided for the individual components and are given in the drawing, e.g. **1**, in the text in brackets, for example (1).
- Multiple position numbers, i.e. alternative components, are represented with a slash: e.g. **1/2**.

### Arrows

- ➔ Arrow representing an action
- ➞ Forces

---

## Presentational Reference

The illustration on the front cover of these instructions is understood to be a system representation only. The assembly steps presented in these Instructions for Assembly and Use are shown in the form of examples with only one component size. They are valid accordingly for all component sizes contained in the standard configuration.

For a better understanding, detailed illustrations are partly incomplete. Safety installations may not have been included in these detailed drawings, but must be used nevertheless.

## Target Groups

### Contractors

These Instructions for Assembly and Use are designed for contractors who use the scaffolding either for

- assembling, modifying and dismantling operations, or
- use it, e.g. for concreting, or
- who have it used, e.g. for forming operations.

### Competent person

(Construction Site Coordinator)

The Safety and Health Protection Coordinator\*

- is appointed by the client,
- must identify potential hazards during the planning phase,
- determines measures that provide protection against risks,
- creates a health and safety plan,
- coordinates the protective measures for the contractor and site personnel so that they do not endanger each other,
- monitors compliance with the protective measures.

### Competent person qualified to carry out inspections

Due to the specialist knowledge gained from professional training, work experience and recent professional activity, the competent person qualified to carry out inspections has a reliable understanding of safety-related issues and can carry out inspections correctly. Depending on the complexity of the test to be undertaken, e.g. scope of testing, type of testing or the use of certain measuring devices, a range of specialist knowledge is necessary.

### Qualified persons

The scaffolding may only be assembled, modified or dismantled by personnel who are suitably qualified to do so. For the work to be carried out, the qualified persons must have received instructions\*\* covering at least the following points:

- Explanation of the plan for the assembly, modification or dismantling of the scaffolding in an understandable form and language.
- Description of the measures for safely assembling, modifying or dismantling the scaffolding.

- Designation of the preventive measures to avoid the risk of persons and objects falling.
- Designation of the safety precautions in the event of changing weather conditions that could adversely affect the safety of the scaffolding, as well as the personnel concerned.
- Details regarding the permissible loads.
- Description of any other risks that are associated with the assembly, modification or dismantling procedures.



- **In other countries, ensure that the relevant national guidelines and regulations in the respective current version are complied with!**
- **If no country-specific regulations are available, it is recommended to proceed according to German guidelines and regulations.**
- **A competent person must be present on site during scaffolding operations.**

\* Valid in Germany: Regulations for Occupational Health and Safety on Construction Sites 30 (RAB 30).

\*\* Instructions are given by the contractor himself or a competent person selected by him.

---

## Additional Technical Documentation

- Instructions for Assembly and Use:
  - Slab Formwork
    - MULTIFLEX
    - SKYDECK
    - GRIDFLEX
  - Slab Tables
    - TABLE MODULES
    - VARIODECK
    - SKYTABLE
- Instructions for Use:
  - Pallets and Stacking Devices
- Brochure:
  - PEP Ergo Slab Props
  - PEP 10 Slab Props
  - PEP 20, 30 Slab Props
- PERI Design Tables
  - Formwork and Shoring

## Intended Use

### Product description

PERI products have been designed for exclusive use in the industrial and commercial sectors by qualified personnel only.

PEP Alpha and PEP Alpha-2 Slab Props

- are steel slab props complete with an integrated extension device,
- comply with the load requirements of DIN EN 1065,
- are used as vertical supports for temporary constructions.

### Features

PEP Alpha Slab Props are used in shoring assemblies in a planned perpendicular position to transfer vertical loads. In particular, they also provide support for slab formwork systems.

All components are galvanised.

The following applies to PEP Alpha Slab Props Class D:

- The distance between the pegging holes is 8 cm.
- The adjustment range per pegging is max. 10 cm.

The following applies to PEP Alpha Slab Props Class B, as well as PEP Alpha-2 Slab Props Class B + D:

- The distance between the pegging holes is 10 cm.
- The adjustment range per pegging is max. 12 cm.

Safe working conditions are guaranteed at all times through:

- anti-crush guard
- anti-dropout safeguard on the inner tube

### Technical data

- Props according to DIN EN 1065
- For load-bearing capacities, see Tables

---

## Instructions on Use

Use in a way not intended according to the Instructions for Assembly and Use, or any use deviating from the standard configuration or the intended use, represents a misapplication with a potential safety risk, e.g. risk of falling.

Deviations from the standard configuration must be verified for the application by means of separate strength and stability calculations (Industrial Safety Regulation Appendix 1, No. 3.2.1) and explicitly reflected in the assembly instructions.

Only PERI original parts may be used. The use of other products and spare parts is not allowed.

## Cleaning and Maintenance Instructions

PEP Alpha and PEP Alpha-2 Slab Props have been designed for long-term use on the construction site.

In order to maintain the value and operational readiness of the PERI products over the long term, clean the elements after each use.

Some repair work may also be inevitable due to the tough working conditions. The following points should help to keep cleaning and maintenance costs as low as possible.

Do not clean powder-coated or galvanised components with steel brushes or metal scrapers.

Provide suitable support for the components during cleaning so that no unintentional change in their position is possible.

Do not clean components suspended on crane lifting gear.

Any repairs to PERI products are to be carried out by PERI qualified personnel only.

## Cross-System

### General

The contractor must ensure that the Instructions for Assembly and Use supplied by PERI are available at all times and understood by the site personnel.

These Instructions for Assembly and Use can be used as the basis for creating a risk assessment. The risk assessment is compiled by the contractor. However, these Instructions for Assembly and Use do not replace the risk assessment!

Always take into consideration and comply with the safety instructions and permissible loads.

For the application and inspection of PERI products, the current safety regulations and guidelines valid in the respective countries must be observed.

Materials and working areas are to be inspected on a regular basis, especially before each use and assembly, for:

- signs of damage,
- stability and
- function.

Damaged components must be exchanged immediately on site and may no longer be used.

Safety components are to be removed only when they are no longer required.

Components provided by the contractor must conform with the characteristics required in these Instructions for Assembly and Use, as well as all valid construction guidelines and standards. Unless otherwise indicated, this applies in particular to:

timber components: strength class C24 for solid wood according to EN 338.

scaffold tubes: galvanised steel tubes with minimum dimensions of  $\varnothing 48.3 \times 3.2$  mm according to EN 12811-1:2003 4.2.1.2.

scaffold tube couplings according to EN 74.

Deviations from the standard configuration are only permitted after a further

risk assessment has been carried out by the contractor.

Appropriate measures for working and operational safety, as well as stability, are defined on the basis of this risk assessment.

Corresponding proof of stability can be provided by PERI on request if the risk assessment and resulting measures to be implemented are made available.

Before and after exceptional occurrences that may have an adverse effect regarding the safety of the slab props, the contractor must immediately

- create another risk assessment, with appropriate measures for ensuring the stability of the slab props being carried out based on the results,
- and arrange for an extraordinary inspection by a competent person.

The aim of this inspection is to identify and rectify any damage in good time, in order to guarantee the safe use of the slab props.

Exceptional occurrences can include:

- accidents,
- longer periods of non-use,
- natural events, e.g. heavy rainfall, icing, heavy snowfall, storms or earthquakes.

### Assembly, modification and dismantling work

Assembly, modification or dismantling of shoring may only be carried out by a qualified person under the supervision of a competent person. The qualified persons must have received appropriate training for the work to be carried out with regard to specific risks and dangers.

On the basis of the risk assessment and Instructions for Assembly and Use, the contractor must create installation instructions, in order to ensure safe assembly, modification and dismantling of the slab props.

Before initial use, the safe functioning of the shoring must be checked by a qualified person. The results of the inspection must be documented in an inspection record.

The contractor must ensure that the personal protective equipment required for the assembly, modification or dismantling of the slab props, e.g.

- safety helmet,
- safety shoes,
- safety gloves,
- safety glasses,

is available and used as intended.

If personal protective equipment against falling from a height (PPE) is required or specified in local regulations, the contractor must determine appropriate attachment points on the basis of the risk assessment.

The contractor stipulates the PPE to be used to prevent falling.

The contractor must

- provide safe working areas for site personnel, which are to be reached through the provision of safe access ways. Areas of risk must be cordoned off and clearly marked.
- ensure stability during all stages of construction, in particular during assembly, modification and dismantling operations.
- ensure and prove that all loads can be safely transferred.

### Utilisation

Every contractor who uses or allows slab props or sections of the slab props to be used, is responsible for ensuring that the equipment is in good condition.

If the slab props are used successively or at the same time by several contractors, the health and safety coordinator must point out any possible mutual hazards and all work must be then coordinated.

## System-Specific

Retract components only when the concrete has sufficiently hardened and the person in charge has given the go-ahead for striking to take place.

Anchoring is to take place only if the anchorage has sufficient concrete strength.

## Storage and Transportation

Store and transport components ensuring that no unintentional change in their position is possible. Detach lifting accessories and slings from the lowered components only if they are in a stable position and no unintentional change is possible.

Do not drop the components.

During the moving procedure

- ensure that components are picked up and set down so that unintentional falling over, falling apart, sliding, falling down or rolling is avoided.
- no persons are allowed to remain under the suspended load.

For transportation, the surface used must have sufficient load-bearing capacity.

Use only suitable lifting accessories, as well as the designated load-bearing points.

During the lifting and moving procedure, ensure that all loose parts are removed or secured.

Deliveries of PEP Alpha Slab Props carried out by PERI usually take place in the form of bundles with a maximum of 50 slab props each. These are tied together by means of steel straps.

Deliveries of PEP Alpha-2 Slab Props by PERI take place at the customer's request using pallets containing 42 props each.



**Risk of injury!**  
**Attaching lifting accessories to the steel straps is not permitted!**  
(Fig. S1.01)

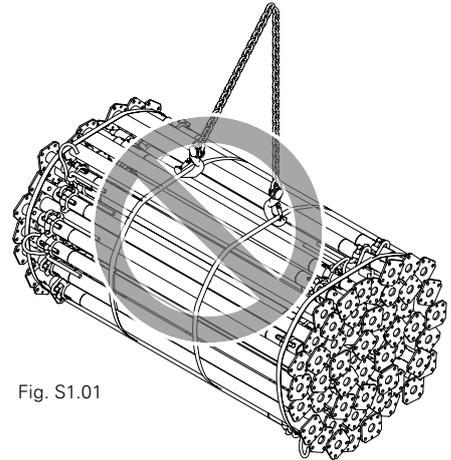

Fig. S1.01



- Transportation units must be correctly stacked and secured!
- Only store and transport props of the same size in one bundle.
- For transportation, the respective national traffic regulations must be complied with at all times.

## Pre-Assembling the slab prop



For the safety of the user, the following should be checked before every use to make sure

- the slab prop is complete,
- the slab prop has no cracks, holes or broken parts,
- the inner tube and adjusting nut are smooth-running and the end plates are level.



- Shown here is the assembly of a free-standing slab prop.
- When used in the system, the respective Instructions for Assembly and Use are to be taken into account, e.g. slab formwork systems

### Pre-assembly

1. Adjust the inner tube (2) of the slab prop to the required height. (Fig. A1.01/A1.01a/A1.02)
2. Turn the inner tube so that the hole in the elongated hole (1b) of the outer tube (1) is visible. (Fig. A1.01 + A1.01a)
3. Insert the G-Hook (3) into the visible hole and slide through the inner tube. (Fig. A1.01a)
4. Turn adjusting nut (4) with grip (4a) to the required size. (Fig. A1.01a)

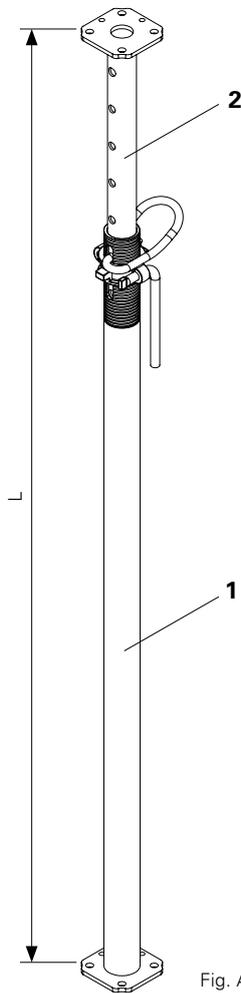

Fig. A1.01

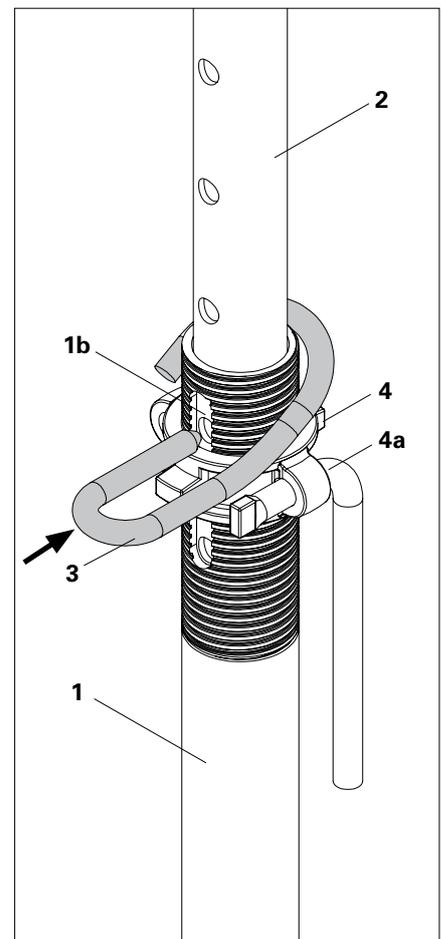

Fig. A1.01a

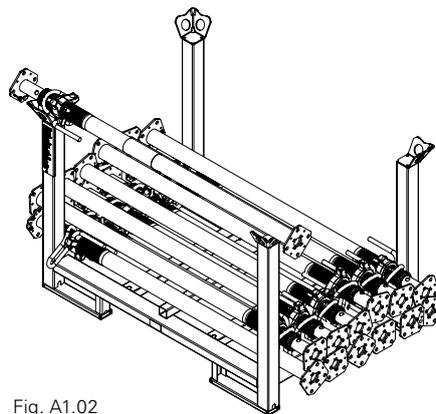

Fig. A1.02



For pre-assembly, place slab prop on a Pallet RP-2. (Fig. A1.02)

## Assembly with Tripod PEP Ergo

For slab props with tube  $\varnothing$  44 – 64 mm.



### Slab prop and tripod

- place on clean, flat and sufficiently load-bearing surface only!
- are not suitable for a planned transfer of horizontal loads!



- Shown here is the assembly of a free-standing slab prop.
- When used in the system, the respective Instructions for Assembly and Use are to be taken into account.
- PEP Ergo Tripods (8) are simply assembly aids for shuttering and striking up to heights of approx. 3 m.

### Tripod assembly

1. Insert pre-assembled slab prop into the tripod (8). (Fig. A1.03)
2. Secure push-pull device (8a) with a hammer. (Fig. A1.03)
3. Ensure that slab prop lies flat against the top and bottom connection plates (8b and 8c). (Fig. A1.03a)



- Check push-pull device to ensure it is firmly in position.
- Slab prop must lie flat on the top and bottom connection plates.
- Slab prop must be in a perpendicular position.

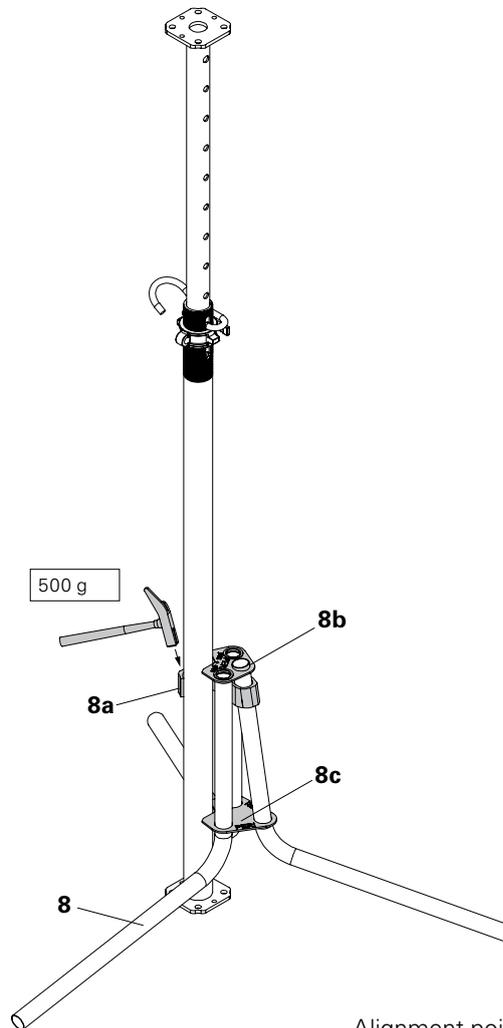

Fig. A1.03

### Alignment points

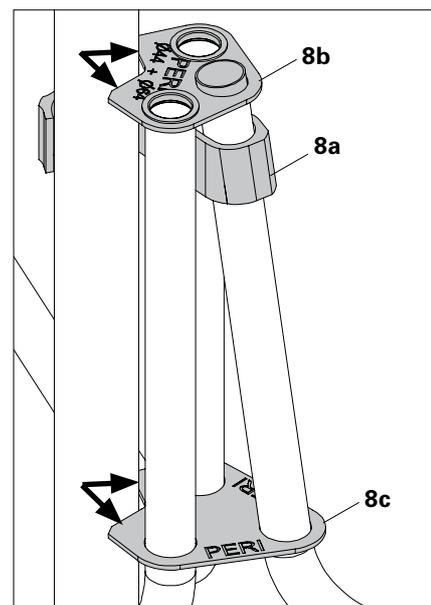

Fig. A1.03a

## Assembly with the Universal Tripod

For slab props with tube  $\varnothing$  57 mm to  $\square$  120 mm.



### Slab prop and tripod

- place on clean, flat and sufficiently load-bearing surface only!
- are not suitable for a planned transfer of horizontal loads!



- Shown here is the assembly of a free-standing slab prop.
- When used in the system, the respective Instructions for Assembly and Use are to be taken into account.
- Universal Tripods (9) are simply assembly aids for shuttering and striking up to heights of approx. 3 m.

### Universal Tripod assembly

1. Insert pre-assembled slab prop into the Universal Tripod (9). (Fig. A1.04)
2. Tighten clamp (9a).
3. Ensure that the slab prop lies flat against the top and bottom connection plates (9b and 9c). (Fig. A1.04a)



- Does the slab prop lie completely flat against the top and bottom connection plates?
- Has the clamp been tightened?
- Is the slab prop in a perpendicular position?

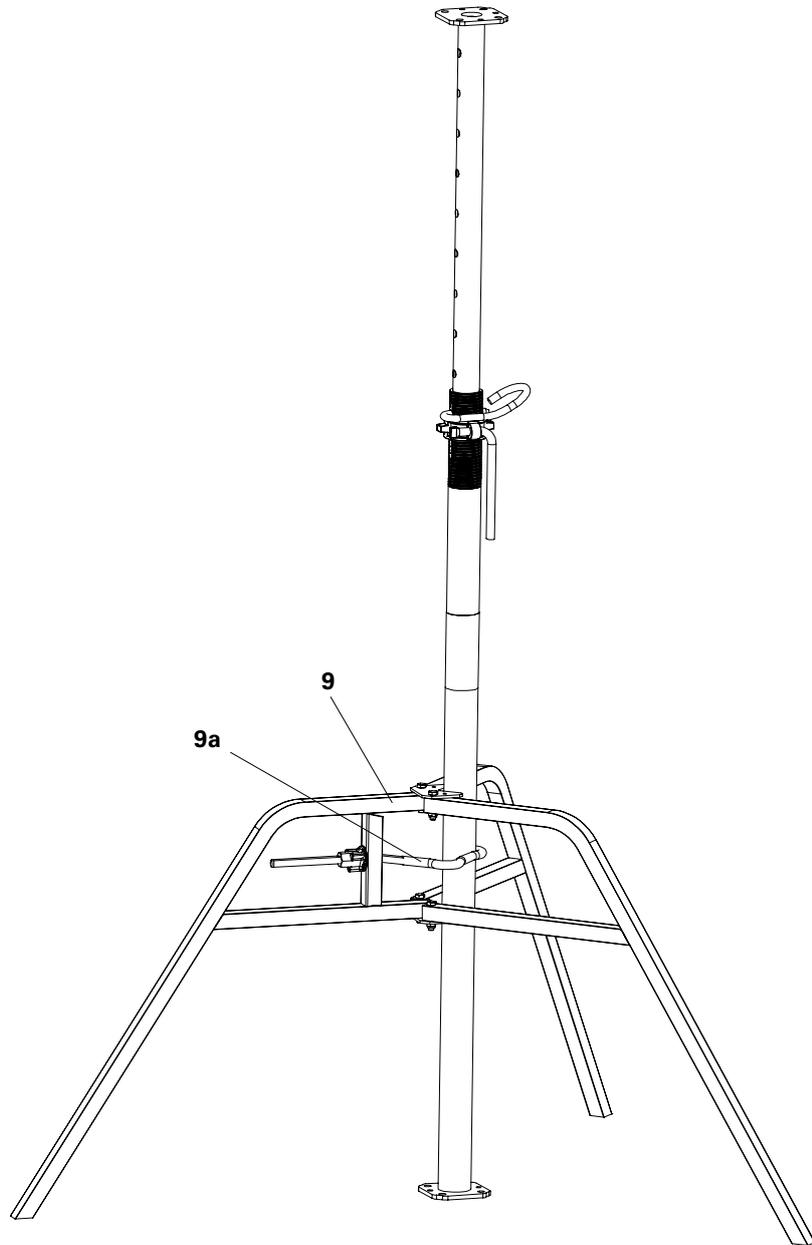

Fig. A1.04

### Alignment points

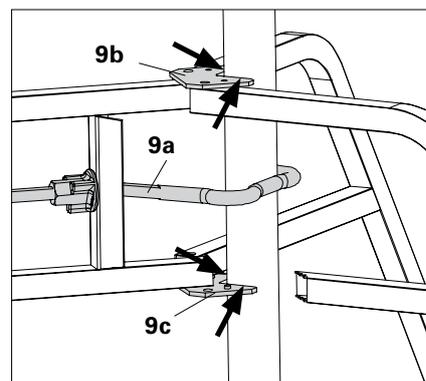

Fig. A1.04a

## Assembly with PEP Frame PRK

For slab props with tube  $\varnothing$  57 - 84 mm.



- Place slab prop on a clean, flat and sufficiently load-bearing surface only!
- Slab props and PEP Frame PRK are not suitable for a planned transfer of horizontal loads!



- Shown here is the assembly with free-standing slab props.
- When used in the system, the respective Instructions for Assembly and Use are to be taken into account.
- PEP Frames PRK (10) are simply assembly aids for shuttering and striking from heights of approx. 4 m.

### PEP Frame PRK assembly

1. Release wedge (10a) on the fasteners (10b) and open clamping jaws (10c). (Fig. A1.05)
2. Insert pre-assembled slab prop between the fastener and clamping jaws. (Fig. A1.06)
3. Close clamping jaw and push wedge downwards. Every frame has 4 fasteners each with one wedge (top and bottom, as well as right and left). (Fig. A1.06 + A1.06a)
4. Mount additional frames on the slab props.
5. Hammer in all wedges (rebound impact). (Fig. A1.06 + A1.06a)



- Have all wedges been securely fixed?
- Are the slab props in a perpendicular position?

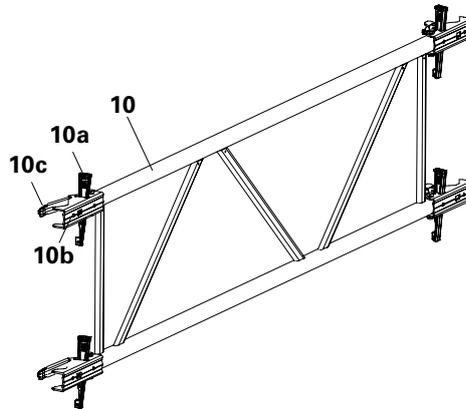

Fig. A1.05

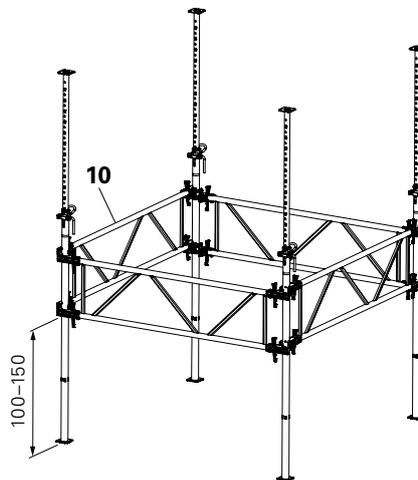

Fig. A1.06

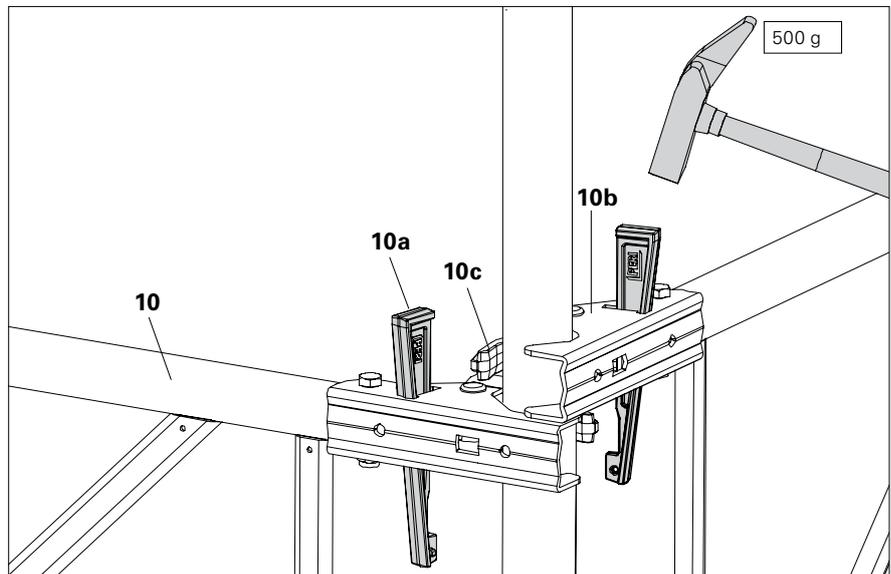

Fig. A1.06a

## Releasing the Slab Prop under Load



In the following, a four-wing adjusting collar is shown as an example. The instructions also apply to the three and two-wing adjusting collars (type-dependent).

### Dismantling:

1. Release adjusting collar and set load free with:
  - Grip (4a) (Fig. A2.01)
  - Hammer impact cam (Fig. A2.02/A2.02a)
  - Wingnut Spanner PEP Item no. 118345 (Fig. A2.03/A2.03a)



**Ensure that the slab prop is completely free of any load.**

2. Hold inner tube firmly and pull out G-Hook. (Fig. A2.02a/A2.03a)
3. Push in inner tube.
4. Place slab prop on the pallet.



See safety instructions for Storage and Transportation



The wingnut spanner allows effortless and noiseless release of the adjusting collar - also with maximum prop load.

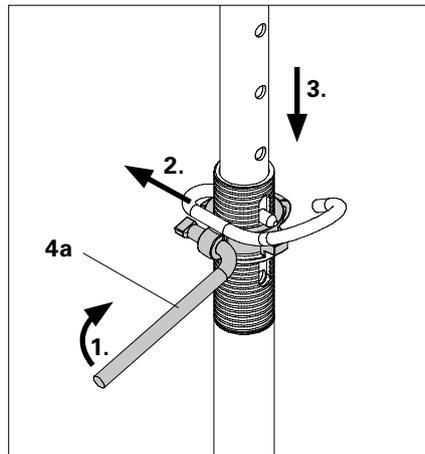

Fig. A2.01

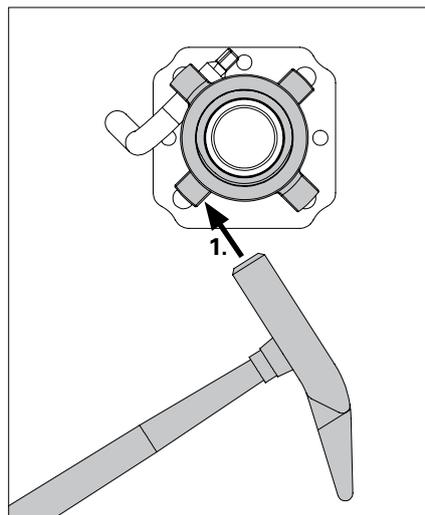

Fig. A2.02

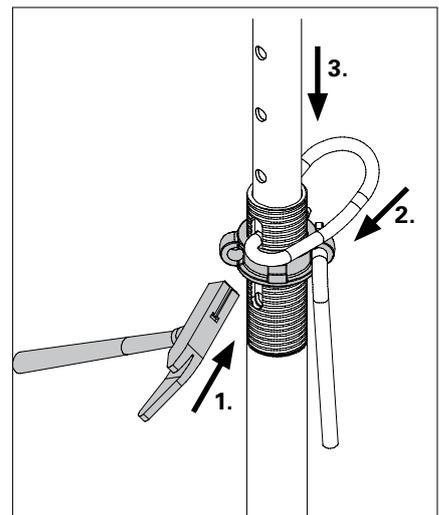

Fig. A2.02a

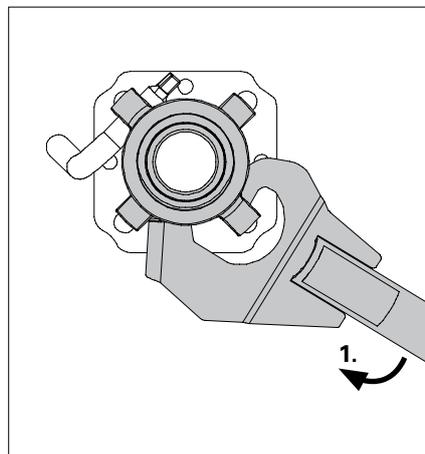

Fig. A2.03

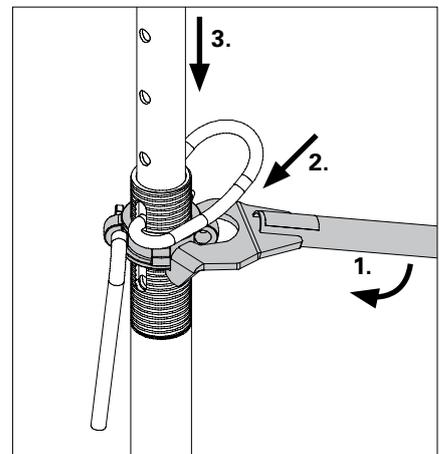

Fig. A2.03a

## Brace Clamp

Used as an alternative assembly aid with high props as of approx. 4 m using bracing boards 3 x 15 cm.



**Brace clamps are not suitable for a planned transfer of horizontal loads!**



- Brace clamps (11) are simply assembly aids for shuttering and striking procedures.
- As an option, tripods can be used as additional assembly aids.

### Assembly

1. Pull narrow side of the wedge (11a) out of the clamp.
2. Place brace clamp (11) around the tube of the slab prop.
3. Insert board in the open side of the clamp.
4. Put wedge back into recess of the clamp and hammer in securely.  
→ The wedge secures the board.
5. Mount additional bracing boards by means of brace clamps. (Fig. A3.01)



Are the slab props in a perpendicular position?  
Have all wedges been securely fixed?  
Are all wedges securing the boards?

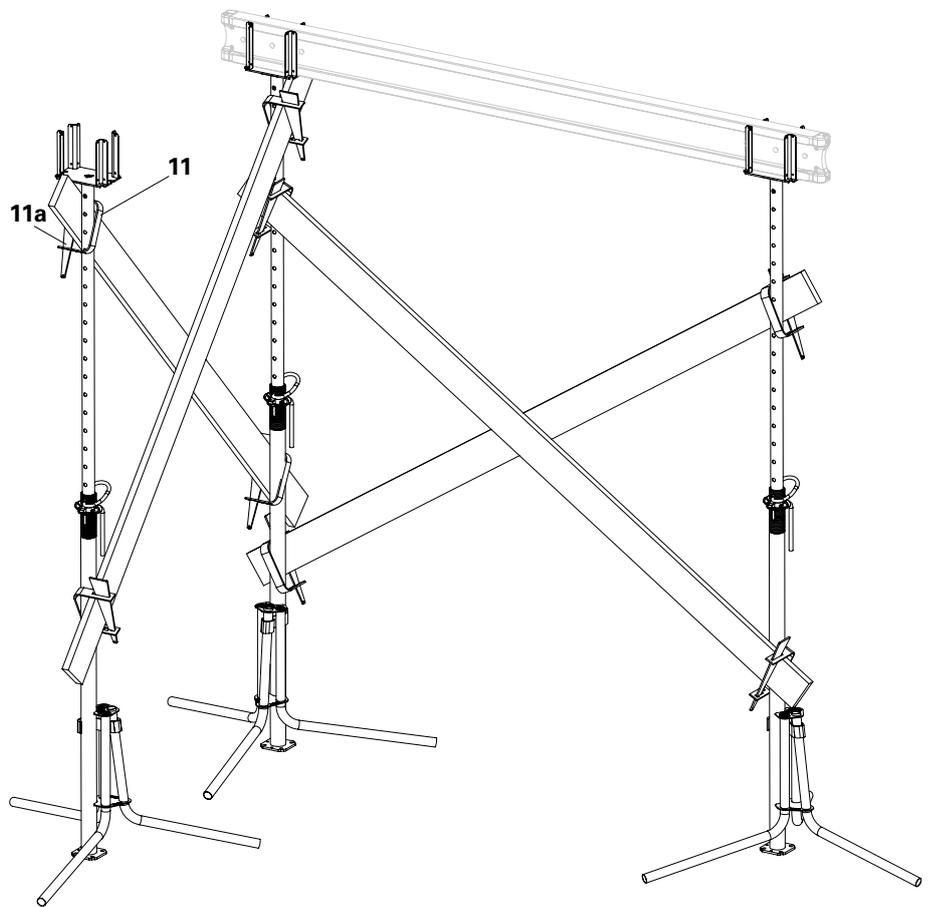

Fig. A3.01



**Applications of this kind or similar are prohibited!**

**Ensure that slab props are always in a perpendicular position!**

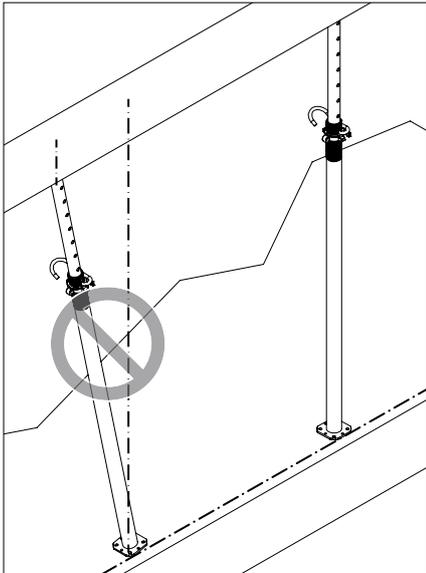

Fig. A4.01

**Only use full-faced support surfaces!**

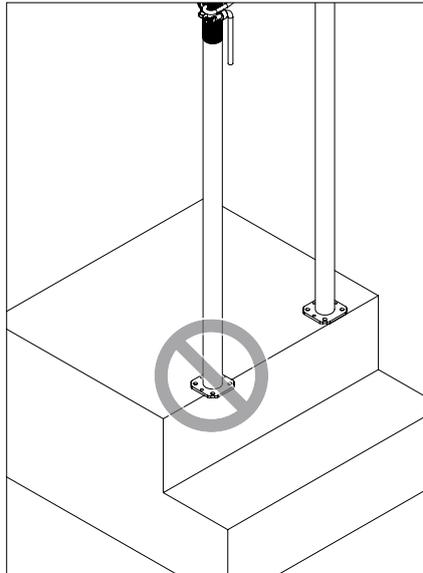

Fig. A4.02a

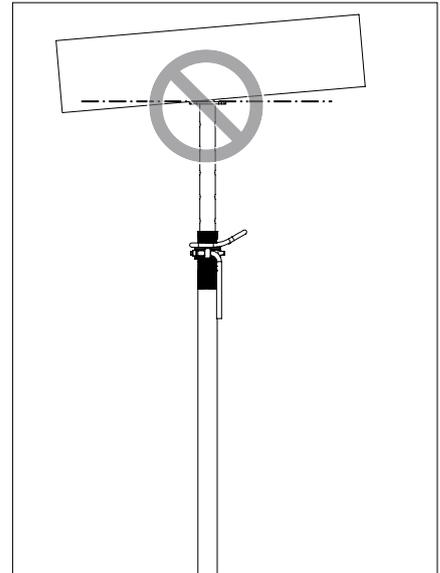

Fig. A4.02b



Slab props must always be in a vertical position.



End plates of the slab props must always lie completely flat. If necessary, fill the gap and secure the wedge.

**Non-loadable installation surface!**

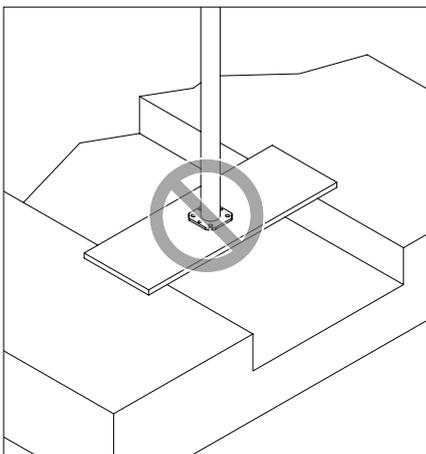

Fig. A4.03a

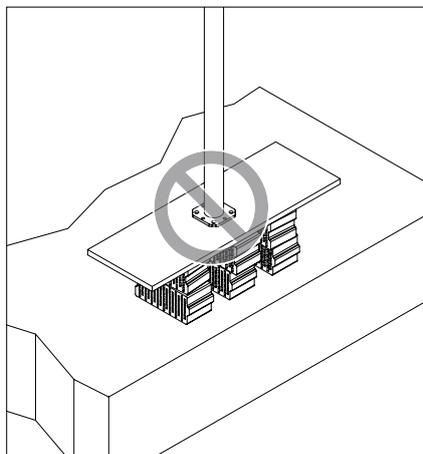

Fig. A4.03b



Slab props must always be positioned on sufficiently load-bearing and level surfaces.

# A4 Foreseeable Misapplications



## Applications of this kind or similar are prohibited!

Do not connect several slab props to each other!

Do not use a tie rod or reinforcement bar instead of a G-hook!

Do not use to support formwork elements!

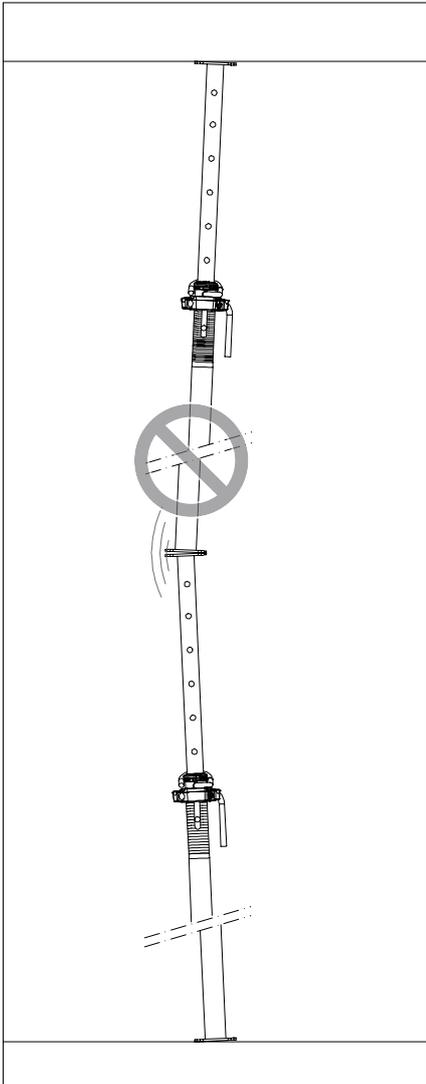

Fig. A4.04

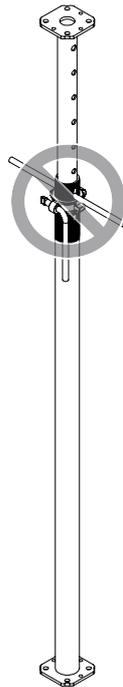

Fig. A4.05



Only use an original G-Hook for pinning the inner tube.

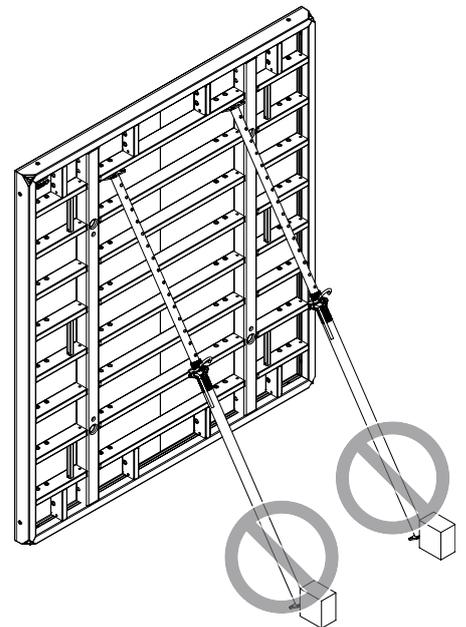

Fig. A4.06



Use designated support equipment, e.g. push-pull props or brace frames.



If the clearance is too large, a longer slab prop or a shoring tower must be used, e.g. MULTIPROP MP or PERI UP Flex.

# A4 Foreseeable Misapplications



**Applications of this kind or similar are prohibited!**

**Do not use as a trench strut!**

**Do not use as anti-fall protection!**

**Do not use as a guardrail holder!**

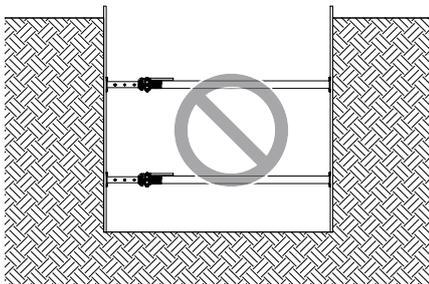

Fig. A4.07

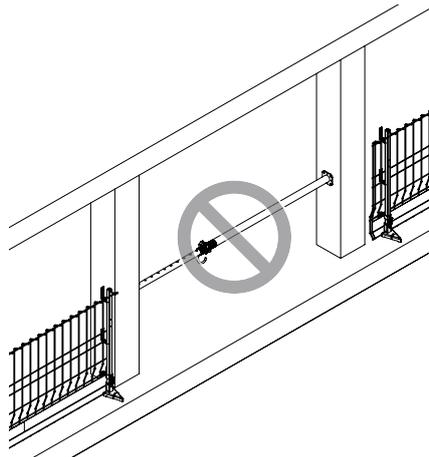

Fig. A4.08

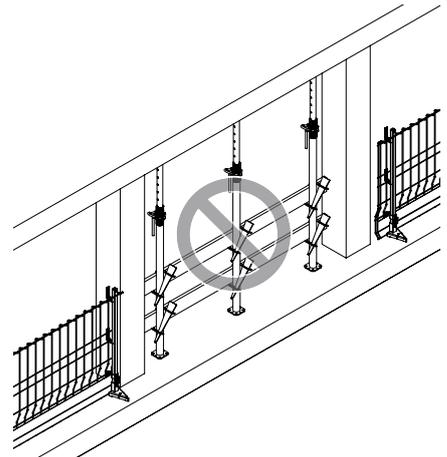

Fig. A4.09



Use designated trench strut.



Use designated anti-fall protection, e.g. PROKIT EP 110.



Use designated anti-fall protection, e.g. PROKIT EP 110.

**Ensure that no water collects inside the tube!**

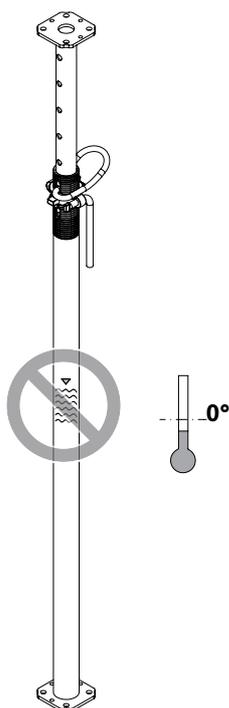

Fig. A4.10



Ensure that water can drain off!  
Do not close the openings!  
Frost will cause the water to freeze.  
Formation of ice can cause the inner tube  
with G-hook to lift.



G-Hook must rest on the adjusting collar!



Permissible prop load [kN]						
Extension length [m]	PEP Alpha		PEP Alpha-2			
	B-300	B-350	B-300		B-350	
	Outer or inner tube bottom	Outer or inner tube bottom	Outer tube bottom	Inner tube bottom	Outer tube bottom	Inner tube bottom
1.70						
1.80	30.0		32.4	32.4		
1.90	30.0		31.7	32.4		
2.00	30.0		30.9	32.4	34.9	34.9
2.10	27.2	30.0	27.9	32.4	34.9	34.9
2.20	24.9	28.9	25.5	32.4	30.1	34.9
2.30	22.6	26.4	23.4	32.4	27.3	34.9
2.40	20.8	24.3	22.6	32.4	25.0	34.9
2.50	19.2	22.4	21.7	30.5	23.3	34.9
2.60	17.7	20.7	20.4	27.2	22.1	34.9
2.70	16.4	19.2	19.0	24.6	21.1	31.5
2.80	15.3	17.8	17.8	22.4	19.7	28.1
2.90	14.2	16.6	16.7	20.7	18.5	25.3
3.00	13.3	15.5	15.5	18.9	17.4	23.1
3.10		14.5			16.5	21.3
3.20		13.6			15.5	19.6
3.30		12.8			14.6	17.7
3.40		12.1			13.3	15.8
3.50		11.4			12.1	14.3



The props fulfil the load-bearing capacity requirements of DIN EN 1065.

Permissible prop load [kN]								
Extension length [m]	PEP Alpha				PEP Alpha-2			
	D-300		D-350		D-300		D-350	
	Outer tube bottom	Inner tube bottom	Outer tube bottom	Inner tube bottom	Outer tube bottom	Inner tube bottom	Outer tube bottom	Inner tube bottom
1.70	36.1	36.1						
1.80	36.1	36.1			36.1	36.1		
1.90	36.1	36.1			36.1	36.1		
2.00	36.1	36.1	36.1	36.1	36.1	36.1	36.1	36.1
2.10	35.6	36.1	36.1	36.1	36.0	36.1	36.1	36.1
2.20	33.8	36.1	36.1	36.1	33.8	36.1	36.1	36.1
2.30	32.1	36.1	36.1	36.1	32.1	36.1	36.1	36.1
2.40	30.9	36.1	36.1	36.1	30.9	36.1	36.1	36.1
2.50	29.7	35.2	36.1	36.1	29.7	36.1	36.1	36.1
2.60	27.5	33.2	35.6	36.1	27.5	34.3	35.7	36.1
2.70	25.5	30.6	33.9	36.1	25.5	30.9	34.3	36.1
2.80	23.6	28.1	32.7	36.1	23.6	28.1	32.9	36.1
2.90	21.9	25.8	31.2	36.1	21.9	25.8	31.8	36.1
3.00	20.6	23.5	29.1	36.1	20.6	23.5	29.8	36.1
3.10			27.3	34.2			27.9	34.3
3.20			25.5	31.4			26.1	32.4
3.30			23.7	28.7			24.4	28.8
3.40			22.1	26.3			22.7	26.5
3.50			20.6	24.2			21.1	24.3



The props fulfil the load-bearing capacity requirements of DIN EN 1065.

# PEP Alpha an PEP Alpha-2 Slab Props



Item no.	Weight kg		D	min. L	max. L
		<b>Slab Props PEP Alpha</b>			
130272	15.900	<b>Slab Prop PEP Alpha D-300</b>	Ø 63.5	1710	3000
130274	19.100	<b>Slab Prop PEP Alpha D-350</b>	Ø 70.0	1960	3500
131769	15.200	<b>Slab Prop PEP Alpha B-300</b>	Ø 60.0	1816	3000
131770	17.700	<b>Slab Prop PEP Alpha B-350</b>	Ø 60.0	2066	3500
131957	13.100	<b>Slab Prop PEP Alpha-2 B-300</b>	Ø 60.0	1721	3000
131949	15.000	<b>Slab Prop PEP Alpha-2 B-350</b>	Ø 60.0	1968	3500
131938	14.700	<b>Slab Prop PEP Alpha-2 D-300</b>	Ø 60.0	1725	3000
131925	18.400	<b>Slab Prop PEP Alpha-2 D-350</b>	Ø 70.0	1974	3500

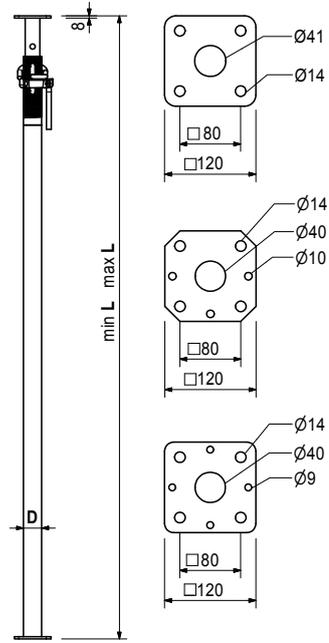
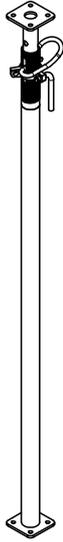

			L	X
		<b>PEP Frames PRK</b>		
111811	13.700	<b>PEP Frames PRK 62.5</b>	723	625
111812	13.900	<b>PEP Frames PRK 75</b>	848	750
112813	15.900	<b>PEP Frames PRK 100</b>	1098	1000
112814	17.800	<b>PEP Frames PRK 120</b>	1298	1200
111813	19.200	<b>PEP Frames PRK 137.5</b>	1473	1375
111814	20.100	<b>PEP Frames PRK 150</b>	1598	1500

Stiffening frame for PEP Slab Props. Complete with captive wedge coupling.

**Note**  
L = Loading Length  
X = Axis Length

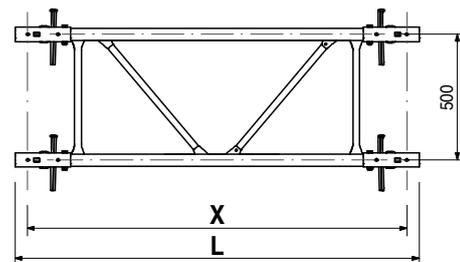
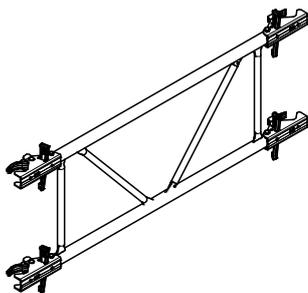

# PEP Alpha an PEP Alpha-2 Slab Props

Item no.	Weight kg
112718	15.300
111815	15.400
112788	15.600
111816	16.100
111817	16.300
111818	17.700
111819	18.700

- PEP Frames PRK**
- PEP Frames PRK 200**
- PEP Frames PRK 201.5**
- PEP Frames PRK 210**
- PEP Frames PRK 225**
- PEP Frames PRK 230**
- PEP Frames PRK 266**
- PEP Frames PRK 296**

Stiffening frame for PEP Slab Props. Complete with captive wedge coupling.

L	X
2098	2000
2113	2015
2198	2100
2348	2250
2398	2300
2758	2660
3058	2960

**Note**

L = Loading Length

X = Axis Length

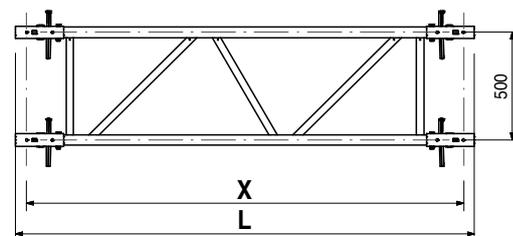
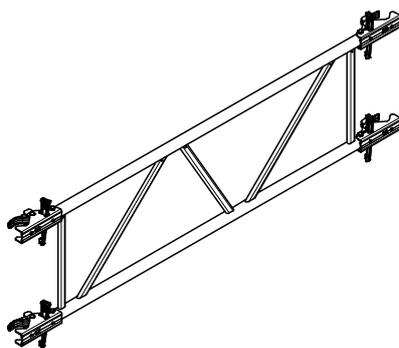

027940	1.840
--------	-------

**Brace Clamp, galv., 48 – 76 mm**

For assembly of 3 x 15 cm stiffening boards at slab props Ø 48 – 76 mm.

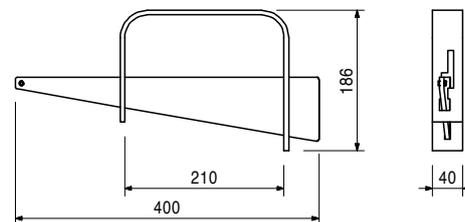
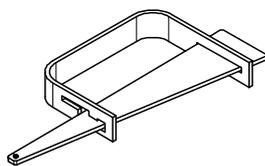

027790	2.460
--------	-------

**Brace Clamp HL, galv., 76 – 120 mm**

For assembly of 3 x 15 cm stiffening boards at slab props Ø 76 – 89 mm and 100 x 100 mm to 120 x 120 mm.

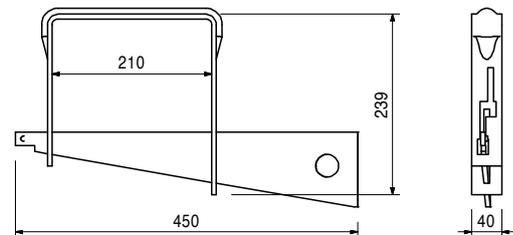
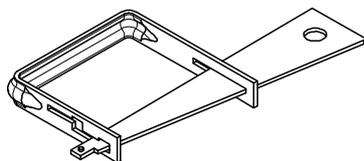

# PEP Alpha an PEP Alpha-2 Slab Props



Item no.	Weight kg
118345	1.500

## Wing Nut Spanner PEP

Allows effortless loosening of the adjusting nut with maximum loaded props.

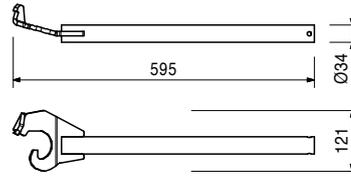
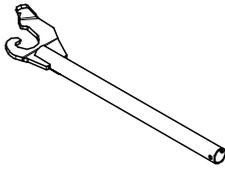

103434	38.500
103429	45.300

## Pallets RP-2, galv

**Pallet RP-2 80 x 120, galv.**

**Pallet RP-2 80 x 150, galv.**

For stacking and transportation of formwork and scaffolding components.

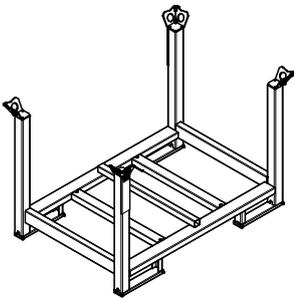

## Note

Follow Instructions for Use!

## Technical Data

Permissible load-bearing capacity 1.5 t.

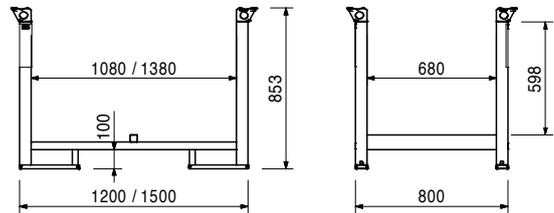

107152	5.810
--------	-------

## Tripod 44 - 64

Erection aid for PEP Ergo Slab Props with Ø 44 – 64 mm.

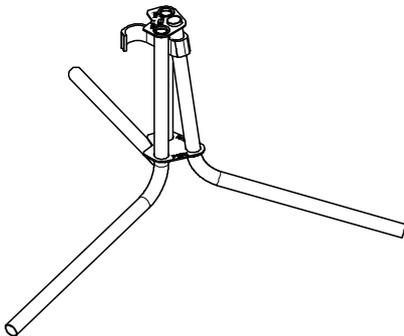

## Note

Only use as erection aid!

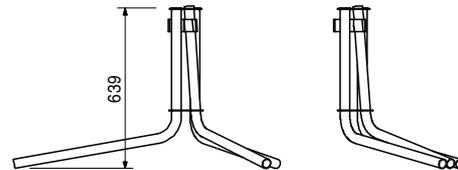

# PEP Alpha an PEP Alpha-2 Slab Props

Item no.	Weight kg
028000	9.190

## Universal Tripod 57 - 120

Erection aid for slab props with  $\varnothing$  57 – 120 mm and 120 x 120 mm. Can also be used in combination with MULTIPROP MP Slab Props and all slab props with Base MP 50.

## Note

Only use as erection aid!

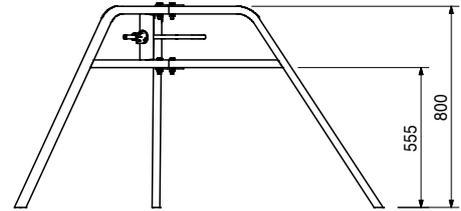
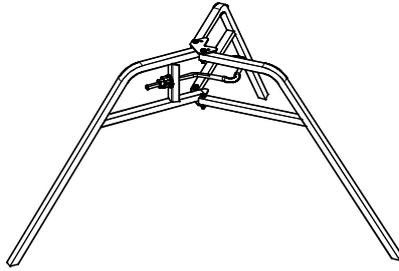

**The optimal System  
for every Project and  
every Requirement**



**Wall Formwork**



**Column Formwork**



**Slab Formwork**



**Climbing Systems**



**Bridge Formwork**



**Tunnel Formwork**



**Shoring Systems**



**Construction Scaffold**



**Facade Scaffold**



**Industrial Scaffold**



**Access**



**Protection Scaffold**



**Safety Systems**



**System-Independent Accessories**



**Services**



**PERI GmbH**  
**Formwork Scaffolding Engineering**  
 Rudolf-Diesel-Strasse 19  
 89264 Weissenhorn  
 Germany  
 Tel. +49 (0)7309.950-0  
 Fax +49 (0)7309.951-0  
 info@peri.com  
 www.peri.com

