

Pretension Jack

for DW 15/20/26

Item no. 030460

## Instructions for use



## Contents

<b>A</b>	<b>Instructions for use</b>	Page
<b>A1</b>	Overview	1
<b>A2</b>	Safety precautions	2
<b>A3</b>	Intended use	3
<b>A4</b>	<b>Utilization</b>	
	1. Determining the tie rod length	4
	2. Assembly for pretensioning	5
	3. Adjust pressure for pretensioning	6
	4. Assembly for withdrawal	7
	5. Adjust pressure for withdrawal	8
<b>A5</b>	Care and maintenance	9
<b>A6</b>	Range of products	10

### Key



Important safety precautions



Note



Visual inspection

## A1 Overview

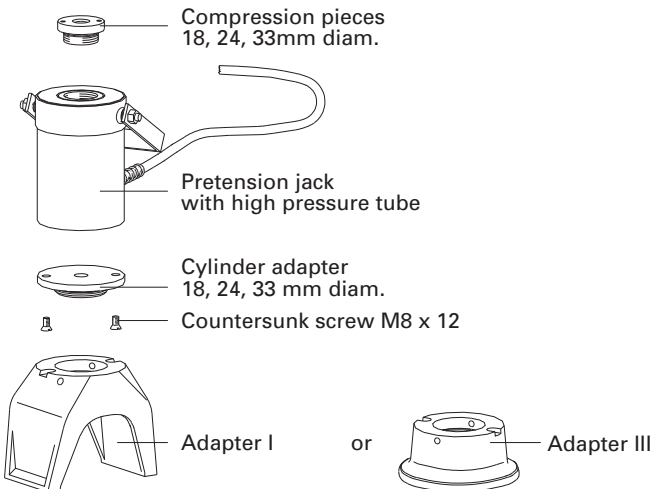
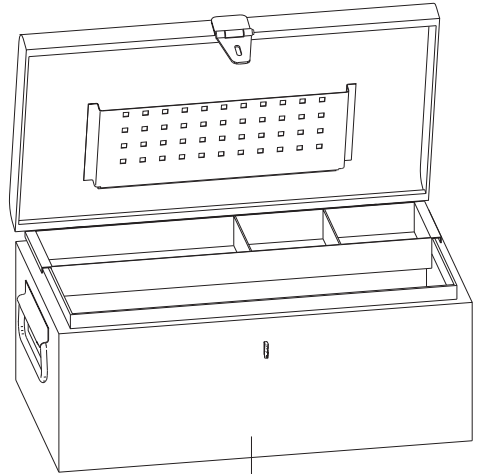
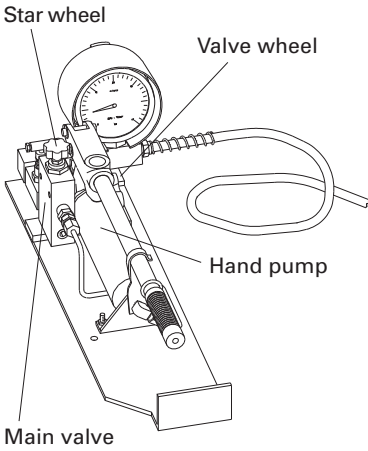

## A2 Safety precautions

**High pressures occur when using the Hi-Force hydraulic appliance. The safety precautions are to be observed to prevent accidents.**

- 1.** The contractor is to make sure that the instructions for use supplied by PERI are available on site and accessible to the authorized persons.
- 2.** The contractor may only authorize persons to independently use the pretension jack who are suitable and experienced for this.
- 3.** The appliances must be inspected for damages and wear and tear before use. Defective appliances are to be immediately set aside.
- 4.** All pretension jacks used on site must be designed for the same operating pressure (700 bar).
- 5.** The maximum operating pressure for the pump or the capacity of the cylinder may not be exceeded. The adjustment of the pressure relief valve on the pump and/or cylinder may not be altered.
- 6.** The system may only be used with one pressure gauge to avoid overloading.
- 7.** The pump can be operated horizontally as well as vertically (pump head below).
- 8.** Evacuate any air in the hydraulic system.
- 9.** Care should be taken that tubes have no damages and that sharp bending, buckling or twists are avoided. Sharp objects should not be dropped on the tubes.
- 10.** The pretension jack may not be carried by the couplings or tubes.
- 11.** The pretension jack may not be exposed to any extreme heat, fire or welding sparks.
- 12.** Impacts on the cylinder are to be avoided.
- 13.** Eccentric loads are to be avoided.
- 14.** Set the base plate on level ground.
- 15.** The contractor is to make sure that the pretension jack is checked at intervals of maximum one year. With frequent use more controls should be carried out.
- 16.** When faults occur the complete pretension jack should be sent to PERI for repair.

## A3 Intended use

The pretension jack is for pretensioning tie rods in girder and panel wall formwork, and for withdrawing or severing embedded anchor rods. It can also be used for anchors built in later.

Especially when using brace frames, the pretension and drilling gauge will be required as an extra part (for installation see instructions for use of PERI rock anchors).

The pretension jack is designed for a tension force (high pressure) of maximum 300 kN. The low pressure (pretension) lies at maximum 100 kN.

The pretension jack consists of a hand pump with pressure relief valve and pressure gauge assembled on a base plate. The pump is connected with the pretension cylinder by a high pressure tube for adjusting the pressure.

The pressure for pretensioning as well as withdrawing the tie rod is adjusted by the star wheel on the main valve. The valve wheel on the pump housing is then closed.

Adapters, cylinder adaptor and compression pieces are supplied in various sizes for the application:

- Compression piece for DW 15, 20 and 26 (18, 24, 33 mm diam.)
- Cylinder adapter for DW 15, 20 and 26 (18, 24, 33 mm diam.)
- Adapters I and III

Other accessories:

- Screwdriver (size 12 x 200)
- Pivot face spanner (size 80/5 – 40/80)
- Oil level dipstick

The pretension jack is supplied as a complete unit in a metal box.

## A3 Preliminary

**Only original parts from PERI may be used as spare parts!**

The applicable safety and environmental regulations of each country are to be observed when using our products.

We reserve the right to make technically advanced alterations.

These instructions for use contain information for the handling and proper use of the PERI pretension jack.

Safety precautions and loading capacity information are to be strictly observed. Any other or excessive use requires our special agreement. Only perfect materials should be used!

Damaged pretension jacks are to be set aside and sent to PERI for repair!

## A4 Utilization

### 1. Determining the length of the tie rod

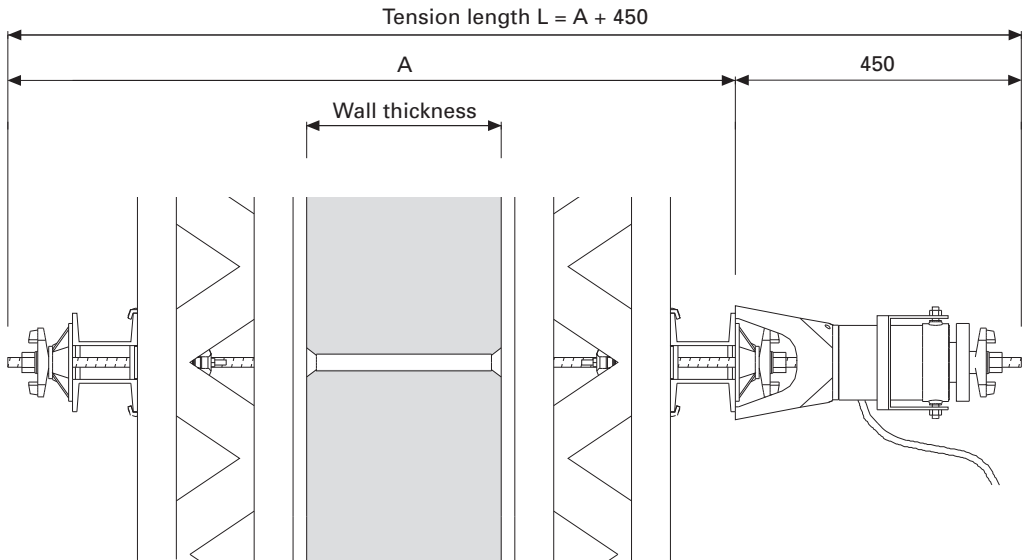

Illust. 1

## A4 Utilization

### 2. Assembly for pretensioning

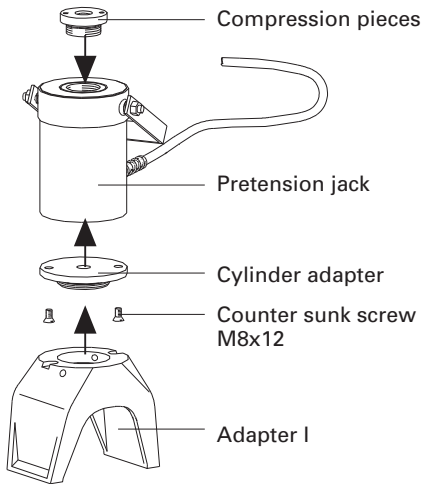

Illust. 2

► Use the appropriate size of 18, 24, or 33mm diam. compression piece and cylinder adapter to centre the tie rods DW 15, 20 or 26.

Thread the **compression piece** into the **pretension jack**. Screw on the cylinder adapter on the opposite side of the pretension jack with the 2 countersunk screws.

Screw the **adapter I** onto the cylinder adapter. Illust. 2

Set the pre-assembled unit on the tie rod of the anchor point. Illust. 3

► Tighten with a **counter plate** and **wing nut**. The use of a wing nut pivot plate is not permitted! The adapter I is designed so that the **nut** can be later tightened on the anchor point.

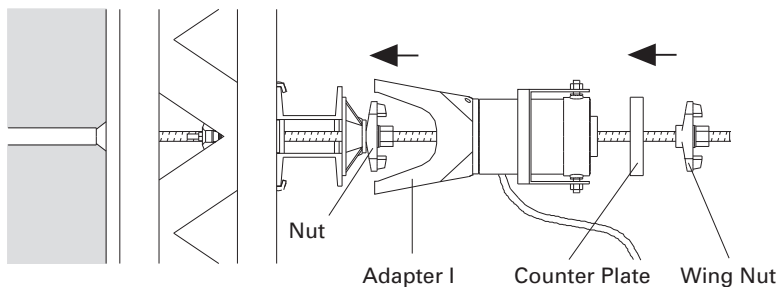

Illust. 3

The instructions for use are to be observed when pretensioning anchors with the PERI rock anchor DW 15.



## A4 Utilization

### 3. Adjust pressure for pretensioning tie rods

**⚠ Low pressure of 0 – 100 kN  
 $\hat{=}$  10 t tensile force.**

**➡** The base plate of the hand pump must always stand on a level base.

Close the **valve wheel** on the pump housing by **turning to the right** until it stops.

Open the **star wheel** of the main valve by **turning to the right** until it stops.

Operate the **pump lever** until the piston of the pretension jack produces tension.

Increase pressure by further activating the pump lever until the required tension force is reached.  
 Illust. 4.

**1 Mp  $\hat{=}$  10 kN**

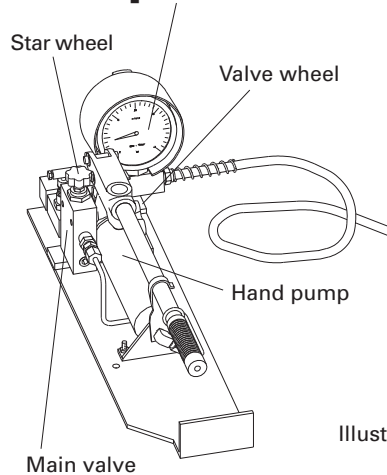

Illust. 4

**⚠ In order to avoid overloading or destroying the pump, the pump lever may not be extended with a pipe.**

**➡** Tighten the **Nut** on the anchor point. Illust. 4.1

Take off the pretension jack: Turn the valve wheel to the left to loosen the pretension force. Remove wing nut and counter plate. Take off the pretension jack and adapter I.

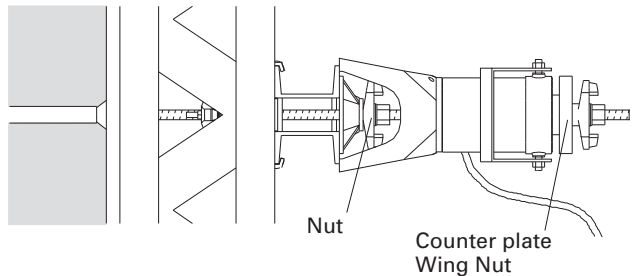

Illust. 4.1



## A4 Utilization

### 4. Assembly for withdrawal

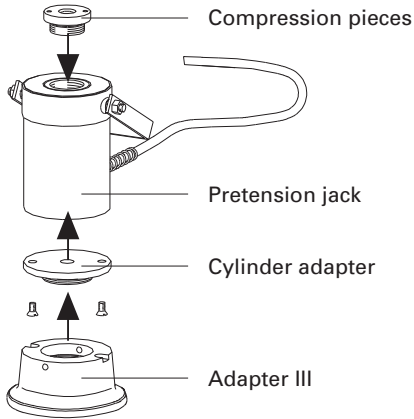

Illust. 5

➡ Use the appropriate size of 18, 24, or 33 m diam. compression piece and cylinder adapter to centre the tie rods DW 15, 20 or 26.

Thread the **compression piece** into the **pretension jack**. Screw on the cylinder adapter on the opposite side of the pretension jack with the 2 countersunk screws.

Screw the **adapter III** onto the cylinder adapter. Illust. 5

Set the pre-assembled unit on the tie rod. Illust. 6

➡ Tighten with a **counter plate** and **wing nut**. The use of a wing nut pivot plate is not permitted!

⚠ **Secure the pretension jack with a cord to prevent it falling.**

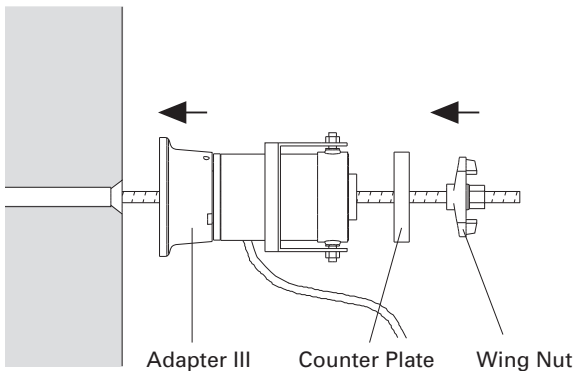

Illust. 6

## A4 Utilization

### 5. Adjust pressure for withdrawing or severing embedded tie rods

**⚠ High pressure of maximum 300 kN  $\hat{=}$  30 t tensile force.**

Close the **valve wheel** on the pump housing by **turning to the right** until it stops.

Turn the **star wheel** of the **main valve** to the **right**.

The more pressure needed, turn more to the right.

Operate the **pump lever** until the piston of the pretension jack produces tension.

Increase pressure by further activating the pump lever until the required tension force is reached. Illust. 7.

**⚠ In order to avoid overloading or destroying the pump, the pump lever may not be extended with a pipe. It is forbidden for anyone to remain near the withdrawal area.**

Take off the pretension jack: Turn the valve wheel to the left to loosen the pretension force. Remove wing nut and counter plate. Take off the pretension jack and adapter. Illust. 7.1

**1 Mp  $\hat{=}$  10 kN**

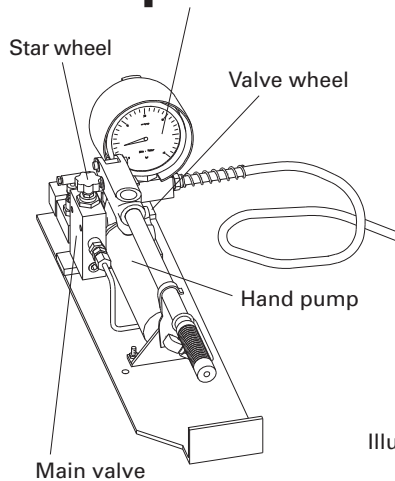

Illust. 7

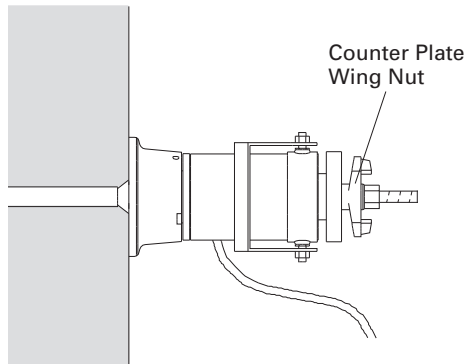

Illust. 7.1

## A5 Care and Maintenance

Except for checking the oil level the pretension jack is maintenance-free.

After use the piston should be completely pushed into the pretension jack and the valve wheel opened (turn to the left).

Avoid soiling the piston of the pretension cylinder, or remove it before pushing home the piston.

Regularly check the oil level. The piston should thereby be pushed home.

Avoid overheating the oil.

When oil is leaking return the pretension jack to PERI for checking. No other hydraulic oil should be used.

The connecting tube between pump and pretension jack may not be removed. (oil loss and air entry).

**Air evacuation:** Close the valve wheel (turn to the right until it stops). Pump out the piston with the pump lever until it stops. Hold the pretension jack so that the piston points downward. Open the valve wheel again. Any air will then go into the tank of the pump. Repeat this process if required.

Do not attempt to disassemble the appliance or to repair it. If there is a fault return the pretension jack to PERI.

## A6 Range of products

Weight kg	Item no.
60,00	030460

### Pretension jack for DW 15/20/26

Maximum tension load:  
30 Mp  $\pm$  300 kN

For smooth vertical concrete joints, and for withdrawing embedded tie rods.

Complete with: Hand pump with pressure relief valve and pressure gauge. Pretension jack with high pressure tube.

Compression pieces 18, 24 and 33 mm diam.

Cylinder adapter

18, 24 and 33 mm diam.

Oil level dipstick.

Screwdriver 12 x 200.

Pivot face spanner 80/5-40/80

Metal box, Adapter I and III

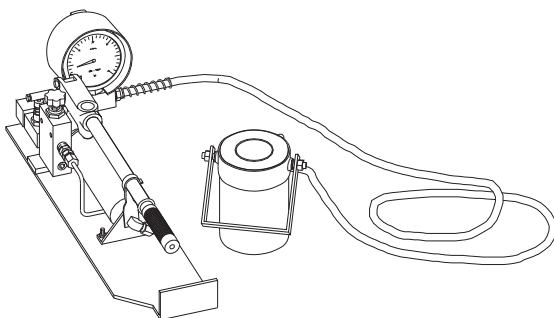

### Adapter I

For pretensioning tie rods.



2,00	030663
------	--------

### Adapter III

For withdrawing embedded tie rods.



1,70	030664
------	--------

### Pretensioning and drilling gauge 45°

For drilling and pretensioning DW 15 anchor points inclined at 45°. (used for brace frame SB).

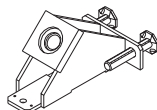

6,52	102390
------	--------

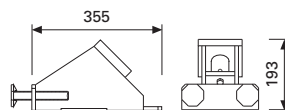

Marking for drilling axis

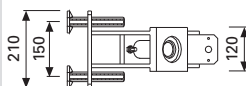

**PERI GmbH**

P. O. Box 12 64  
89259 Weissenhorn  
Tel.: 0 73 09 / 9 50-0  
Fax: 0 73 09 / 9 51-0  
info@peri.de  
www.peri.de